

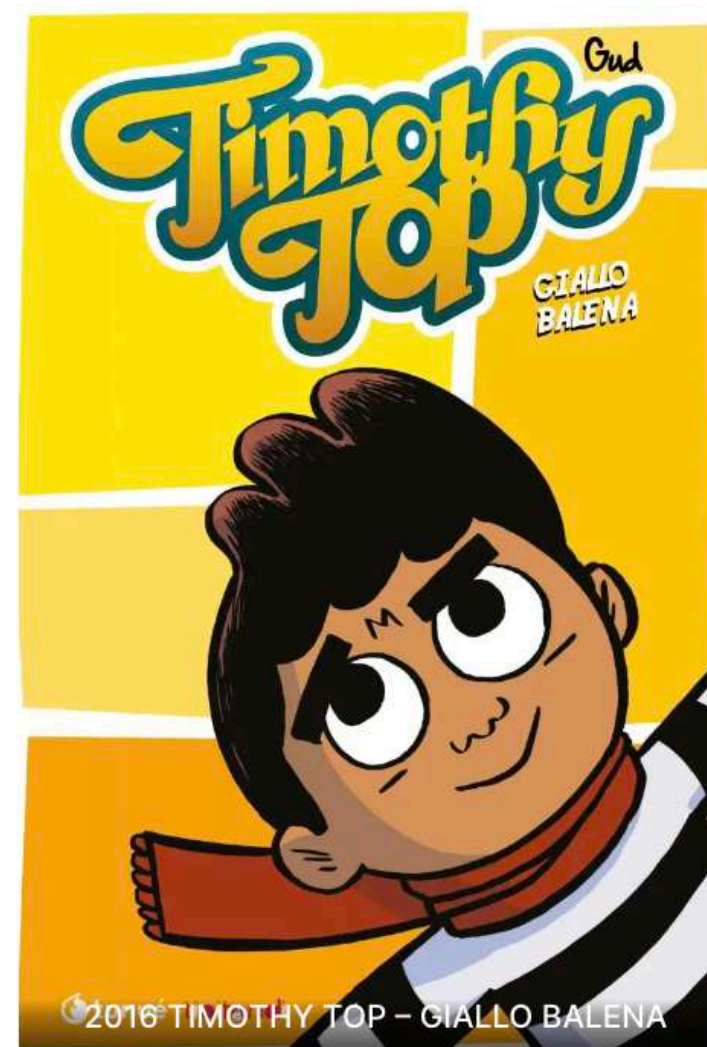

#tuttipossonofarefumetti | [www.gud.it](http://www.gud.it) | [gud@gud.it](mailto:gud@gud.it) | Fb: [gudcomics](https://www.facebook.com/gudcomics) | Tw e Ig: [@guddaman](https://www.instagram.com/guddaman)



2015 TIMOTHY TOP - VERDE CINGHIALE



2016 TIMOTHY TOP - GIALLO BALENA



2018 TIMOTHY TOP - ROSSO PLUMBEE

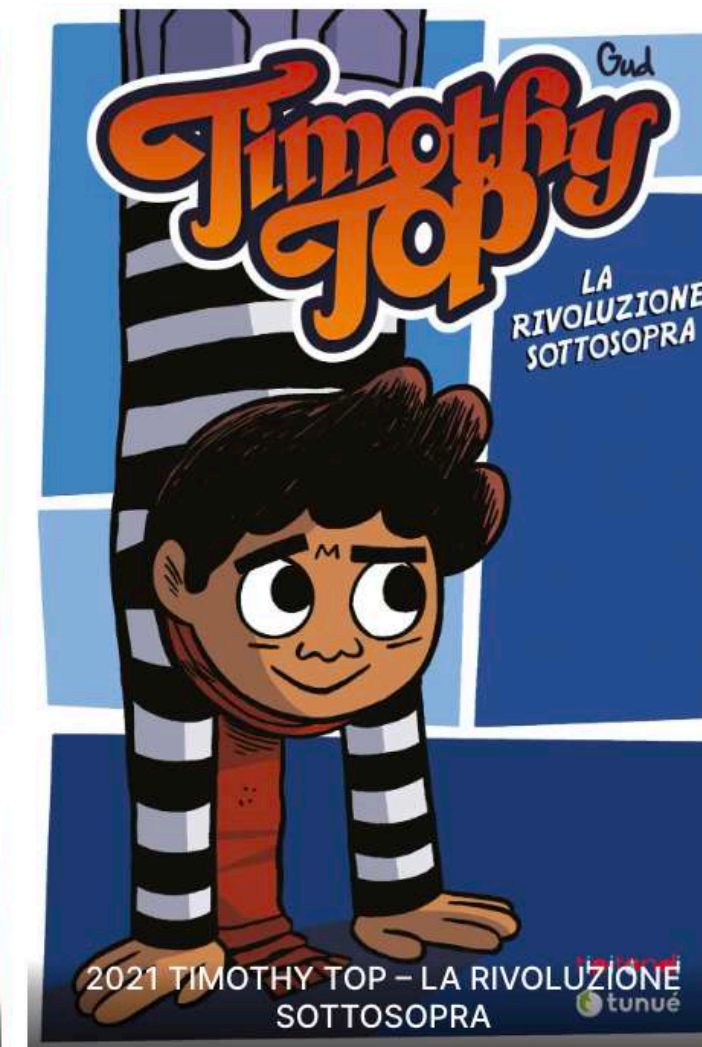

2021 TIMOTHY TOP - LA RIVOLUZIONE SOTTOSOPRA



2011 TUTTI POSSONO FARE FUMETTI

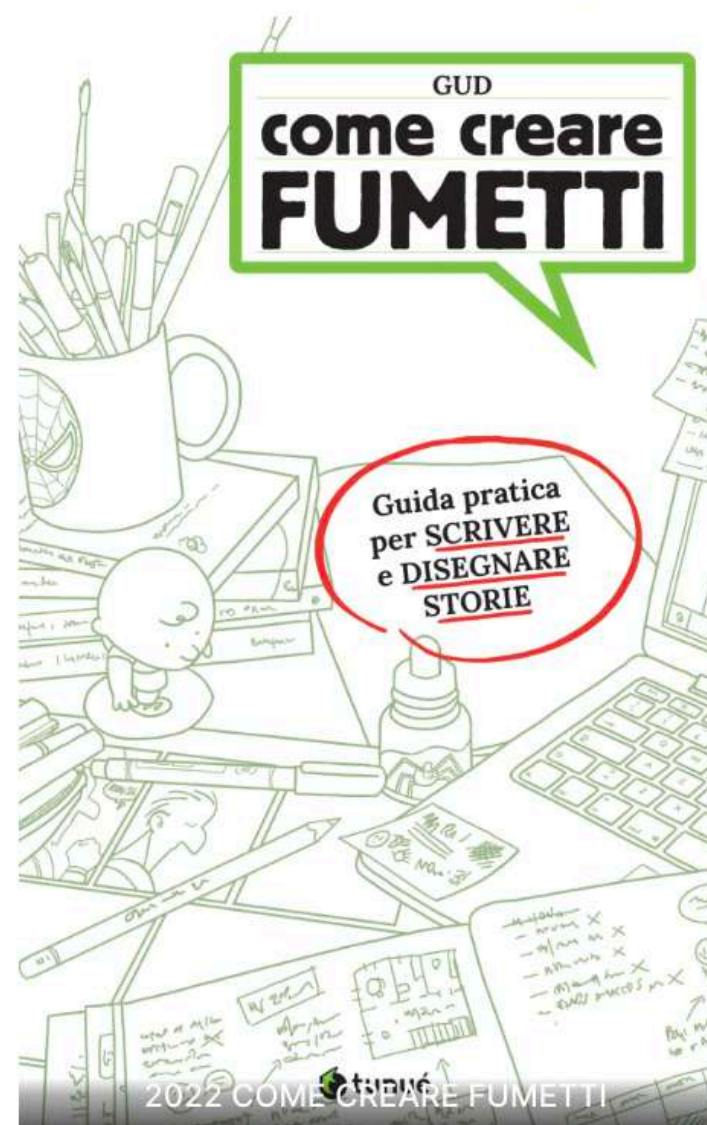

2022 COME CREARE FUMETTI



2020 CHI HA FERMATO IL NATALE?



2022 SE NON TI PIACE LEGGERE QUESTO LIBRO È PER TE

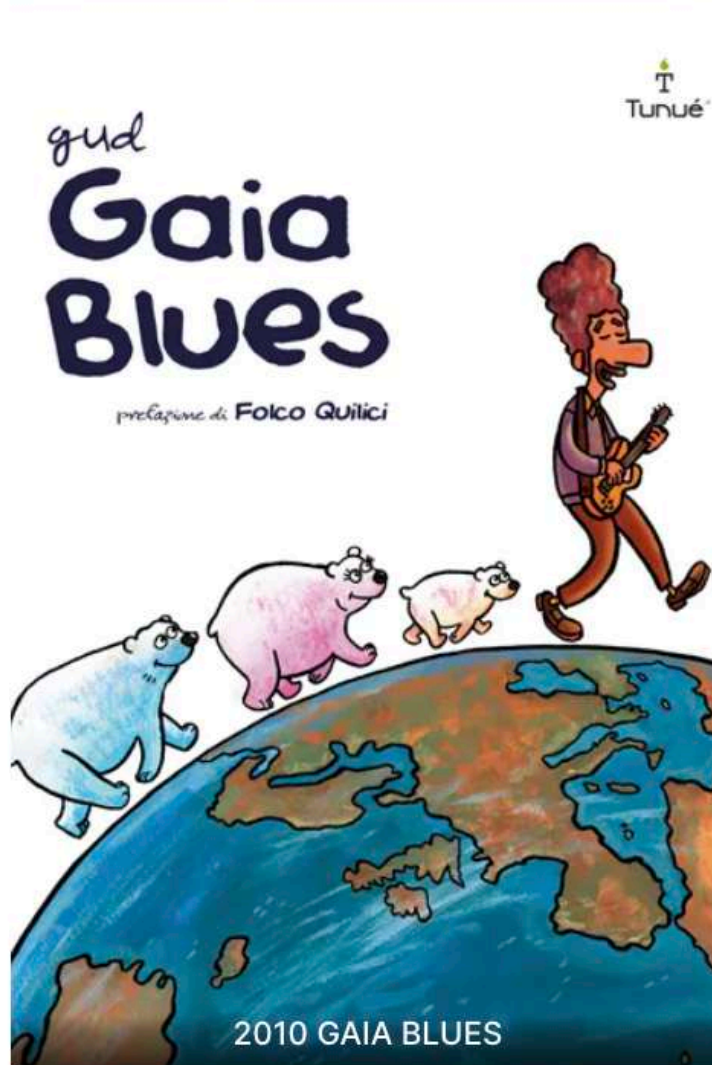
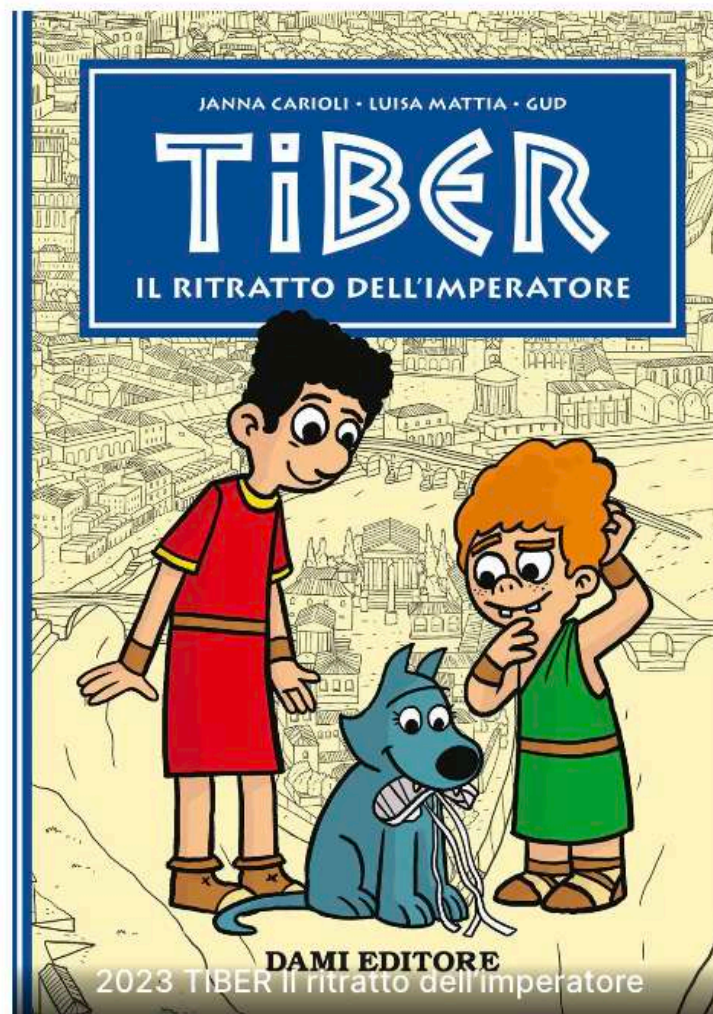
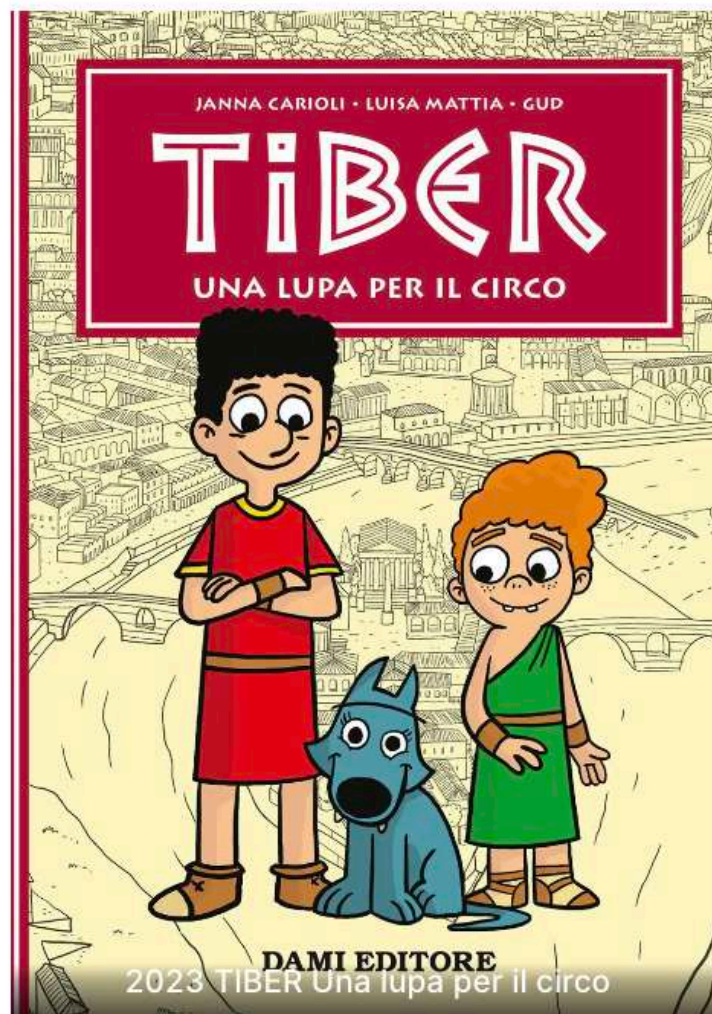

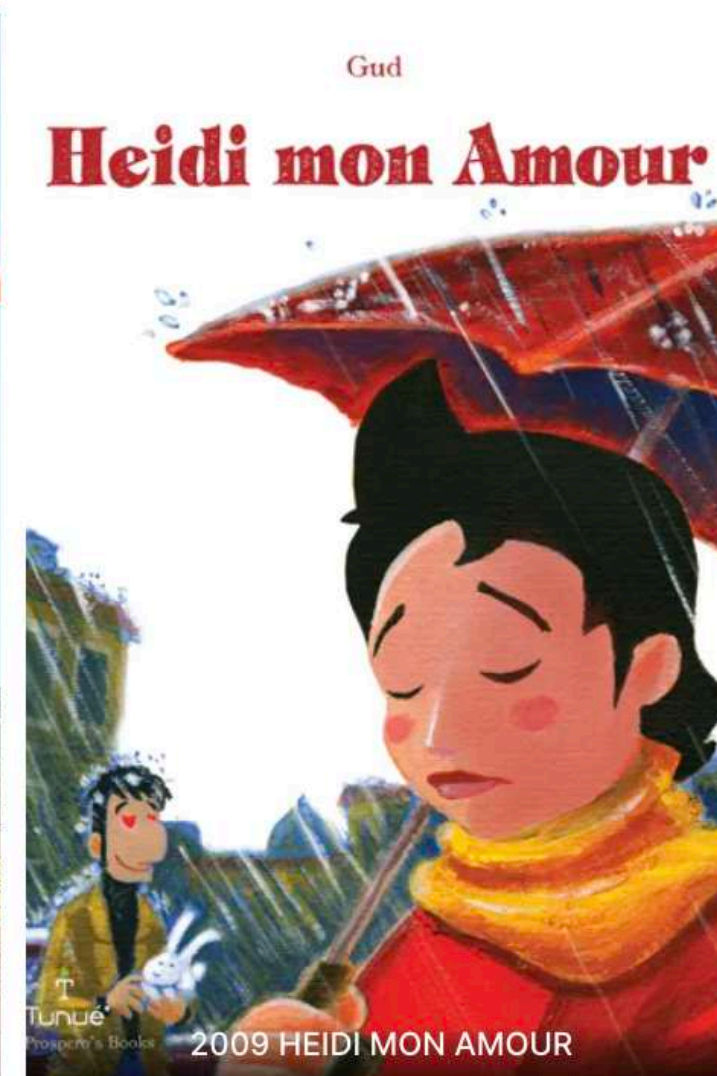
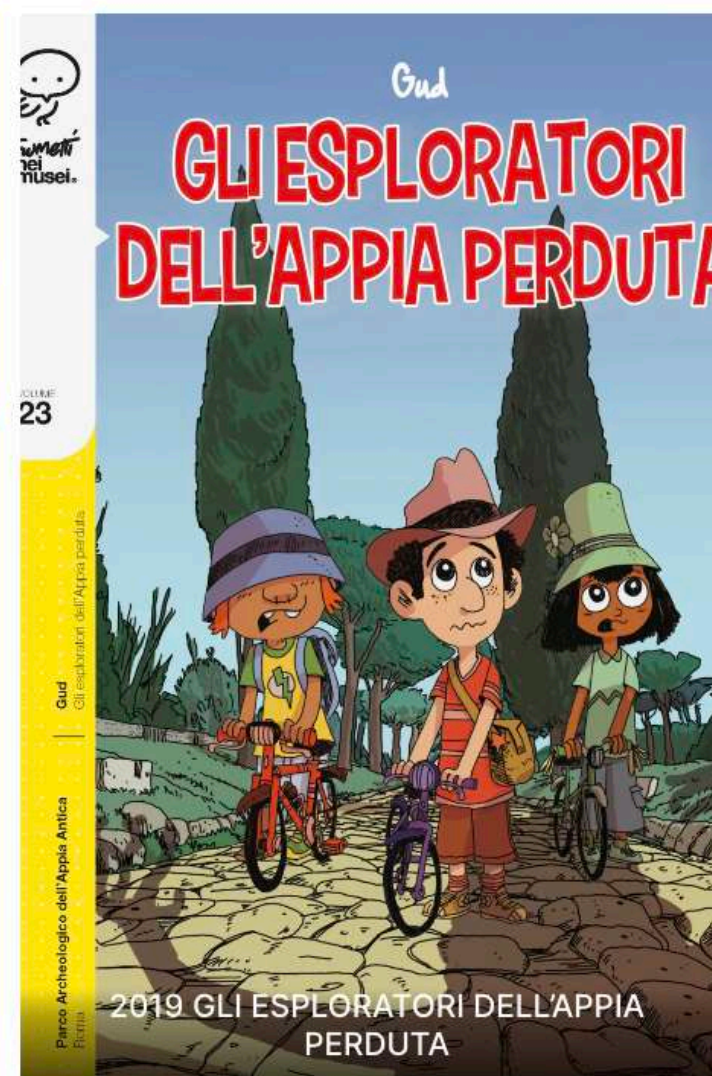
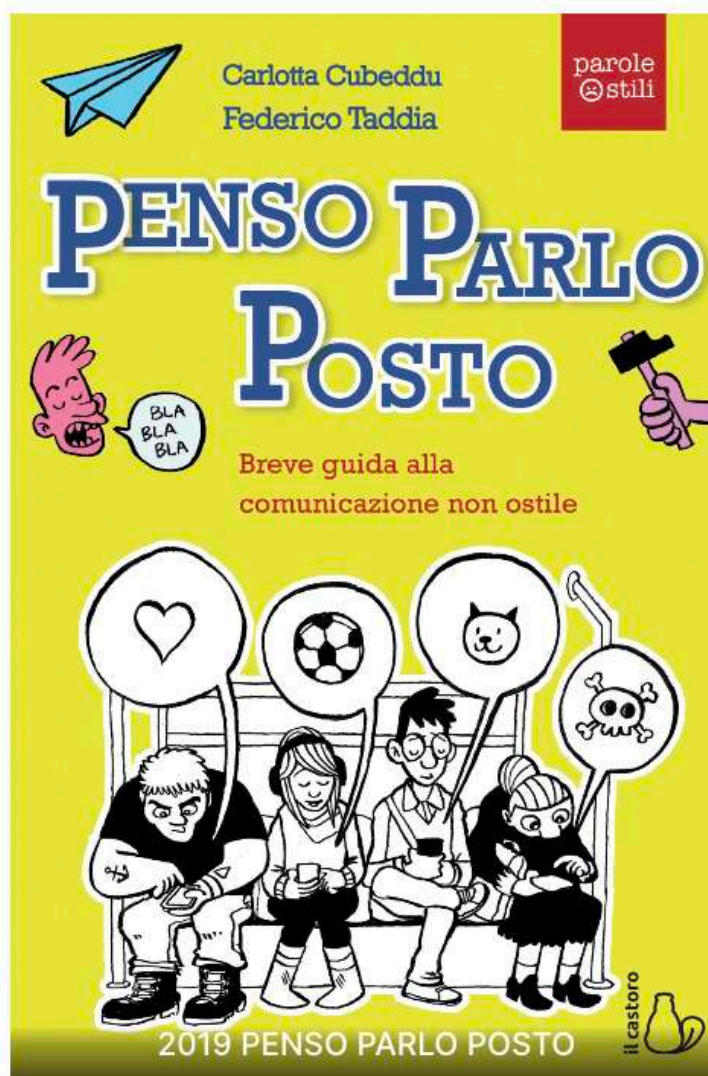

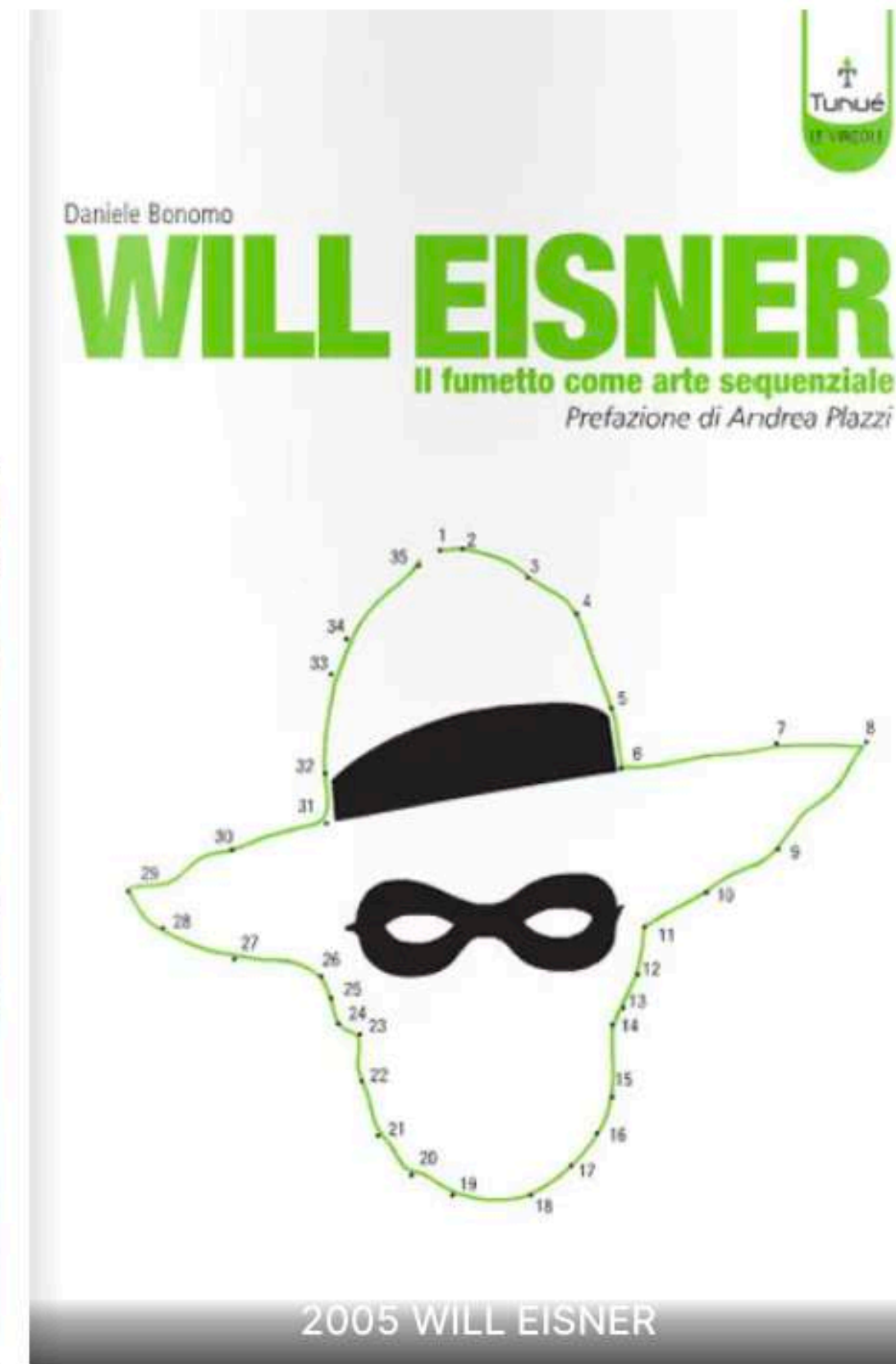
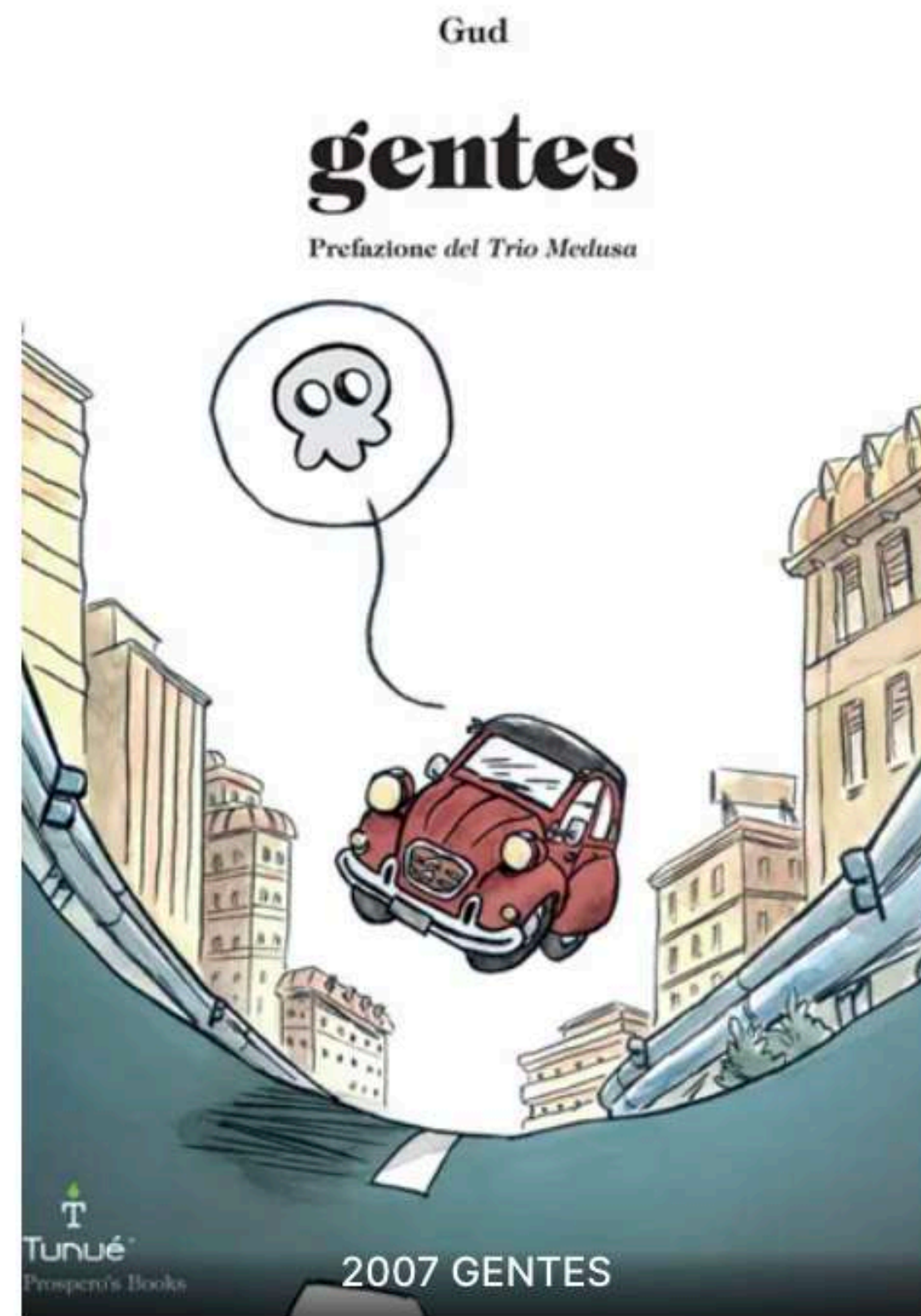

# Cosa è il fumetto?

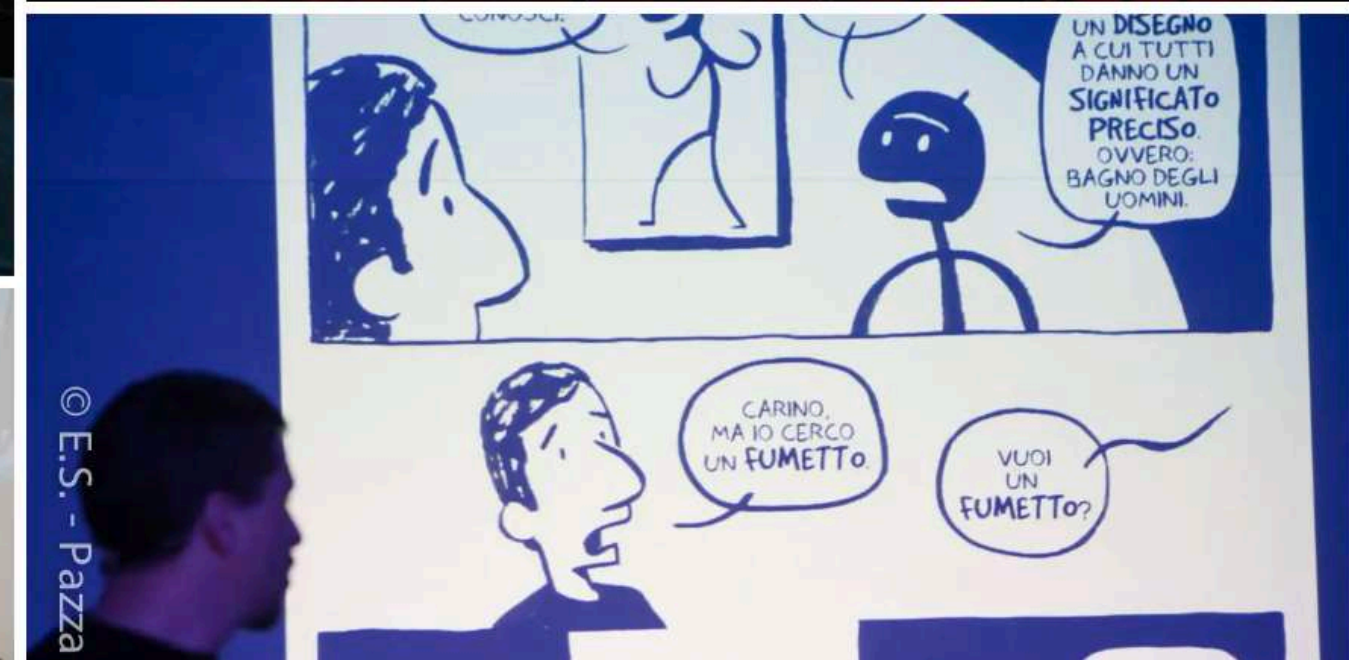

**fùmeo** agg., *lett.*, raro. Fumoso, affumicato: *S'apriva il f. doglio e si saggiava Il vino* (Pascoli). [dal lat. *fumēus*].

**fumettista** s. m. (pl. -i). Autore di racconti o romanzi a fumetti | **fig.** Scrittore impreparato e banale.

**fumettistico** agg. (pl. m. -ci). Caratterizzato da superficialità e ingenuità, spec. nella rappresentazione di vicende o esperienze: *letteratura f.*; *un film di tono fumettistico*.

**fumétto** s. m. 1. Spazio dal contorno simile a quello di una nuvoletta stilizzata, destinato a contenere le parole (che in tal modo paiono uscire di bocca) dei personaggi di racconti o romanzi illustrati; **estens.** (genrl. *al pl.*),

i racconti e i romanzi realizzati con tale tecnica: *preferisce i fumetti ai libri di scuola; quella povera figliola si è montata la testa con la lettura dei f.* | Simbolo di banalità, spec. nella letteratura e nel cinema: *i f. di molti scrittori contemporanei; film fumetto, banale e pieno di luoghi comuni, genrl. a sfondo romanzesco.* 2. Liquore d'anici adoperato per correggere il caffè; mescolato con acqua la rende opalescente (dove il nome). [dim. di *fumo*].

**fumicare** v. FUMIGARE.

**fùmido** agg., *lett.* Offuscato o infestato dal fumo o dalla caligine; fumoso, fumante. [dal lat. *fumidus*].

**fumigante** agg. Che sprigiona





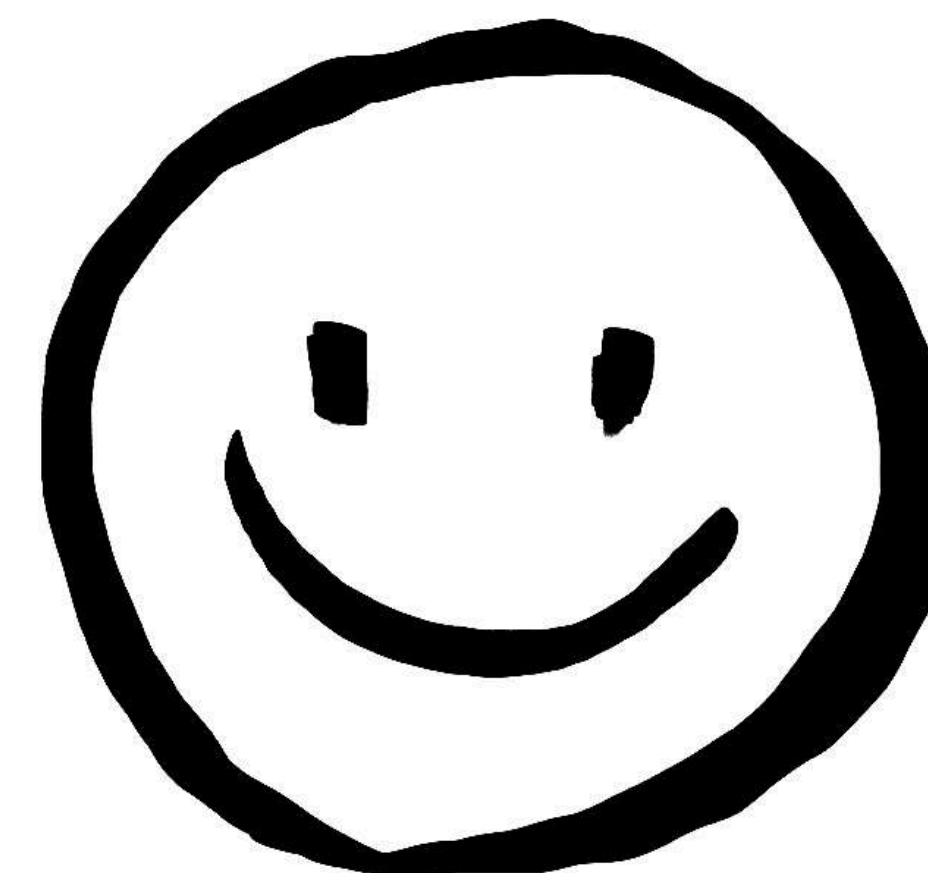
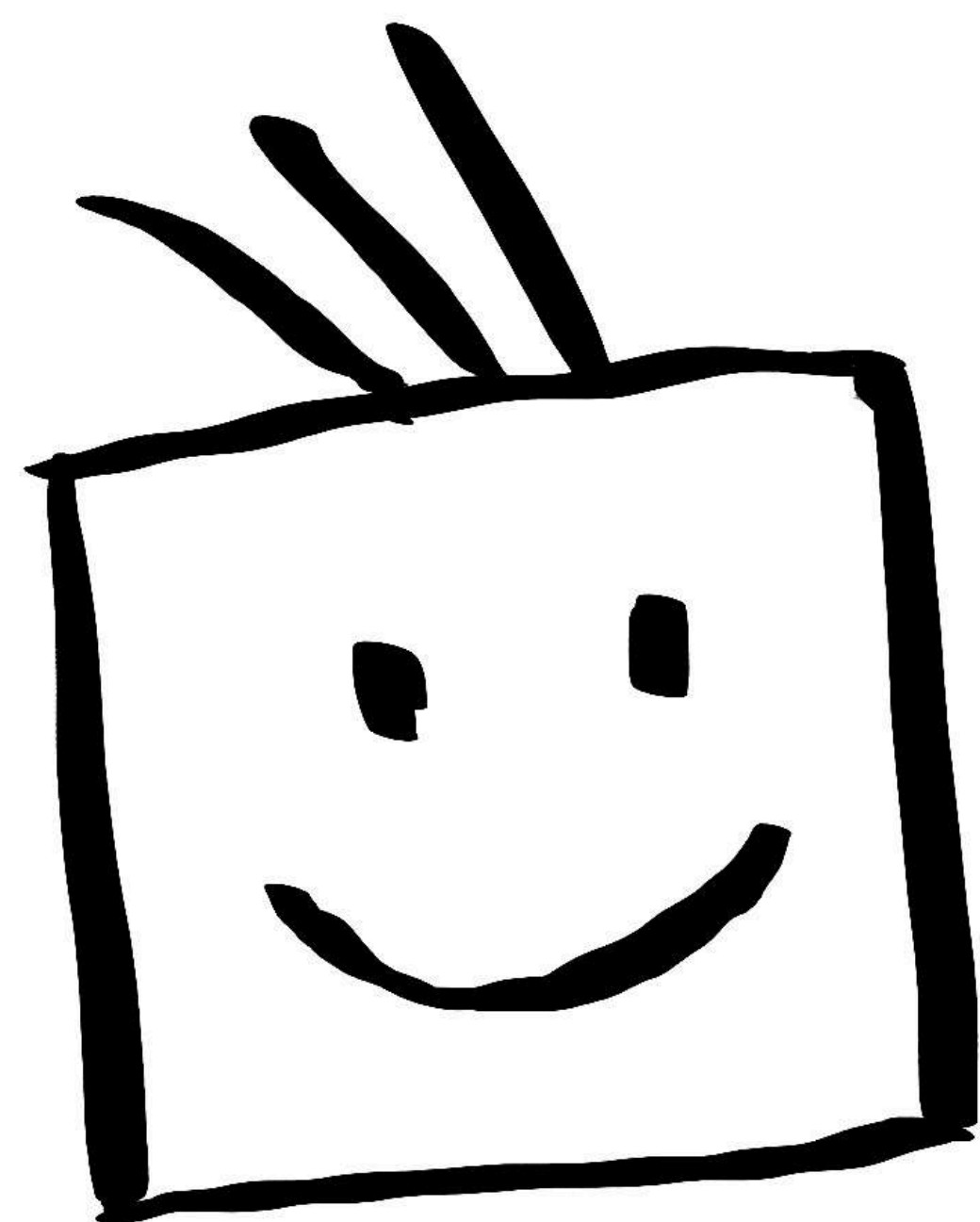

# Fare fumetti = ?

**Fare fumetti = saper disegnare**

**fare fumetti = ~~saper disegnare~~**

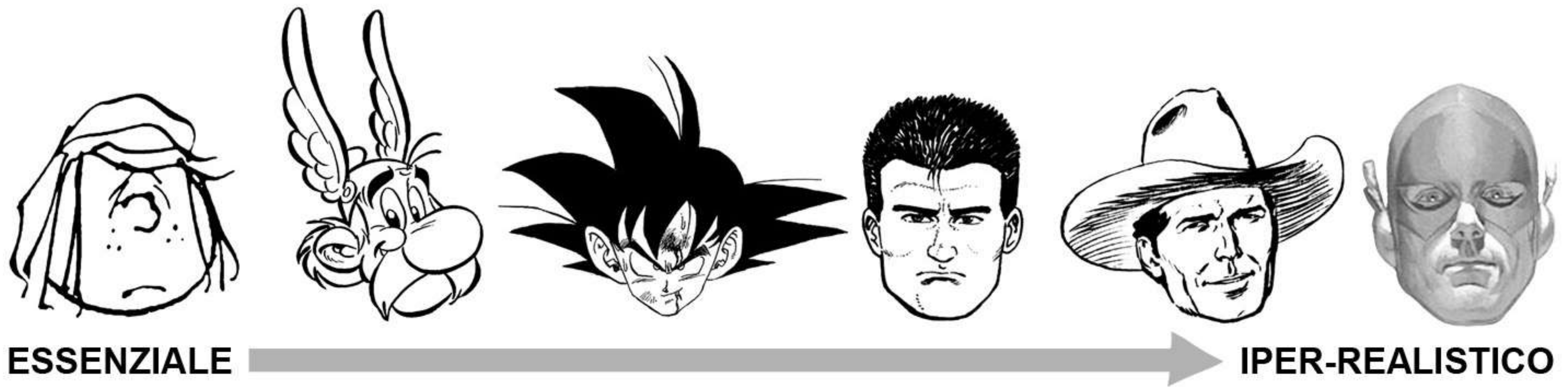

**fare fumetti = saper raccontare**



Comune di Anzio  
Assessorato alla P. I.



II Circolo Didattico di Anzio  
plessso "Acqua del Turco"



# Anzio... da bambini

1ª EDIZIONE

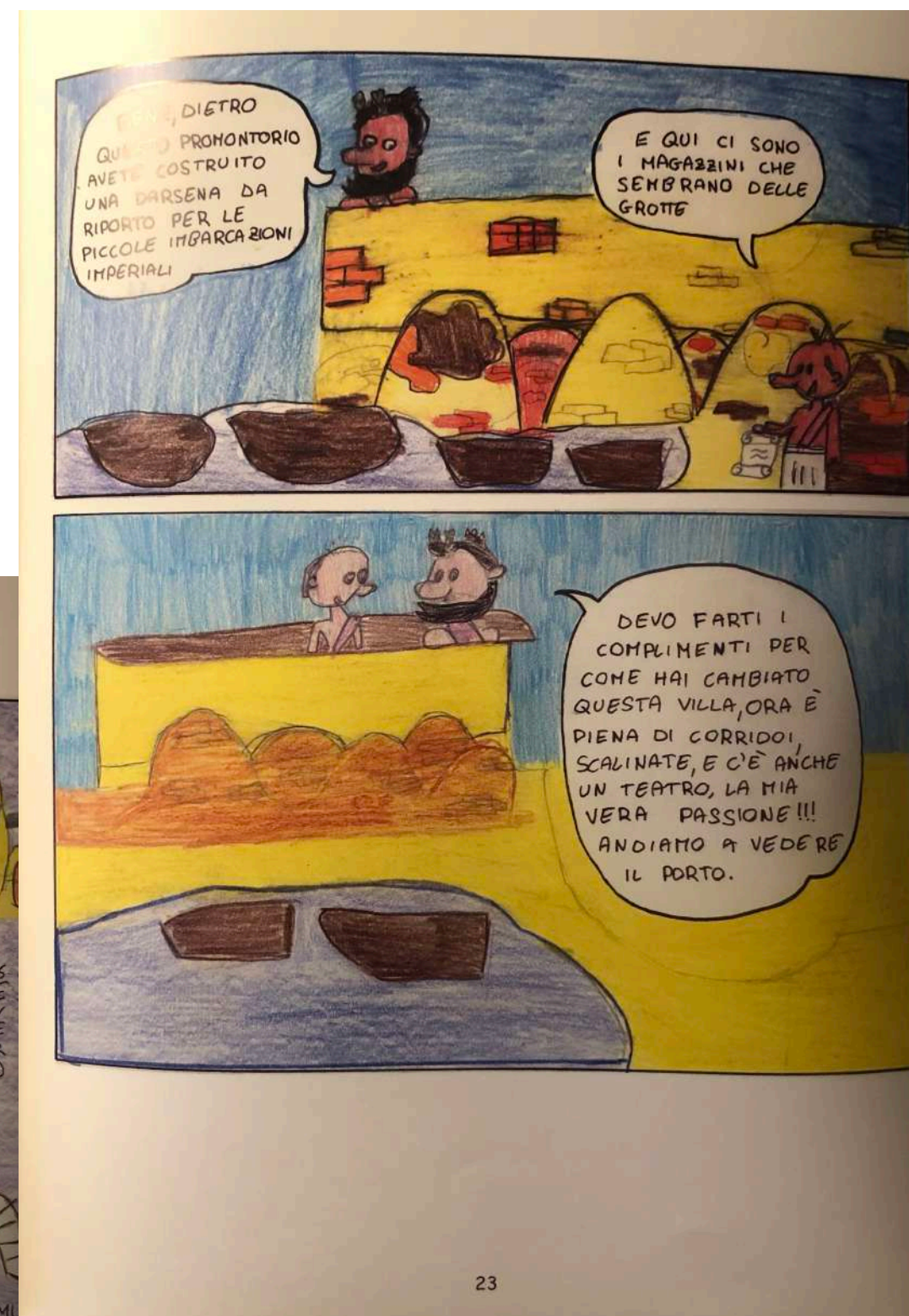
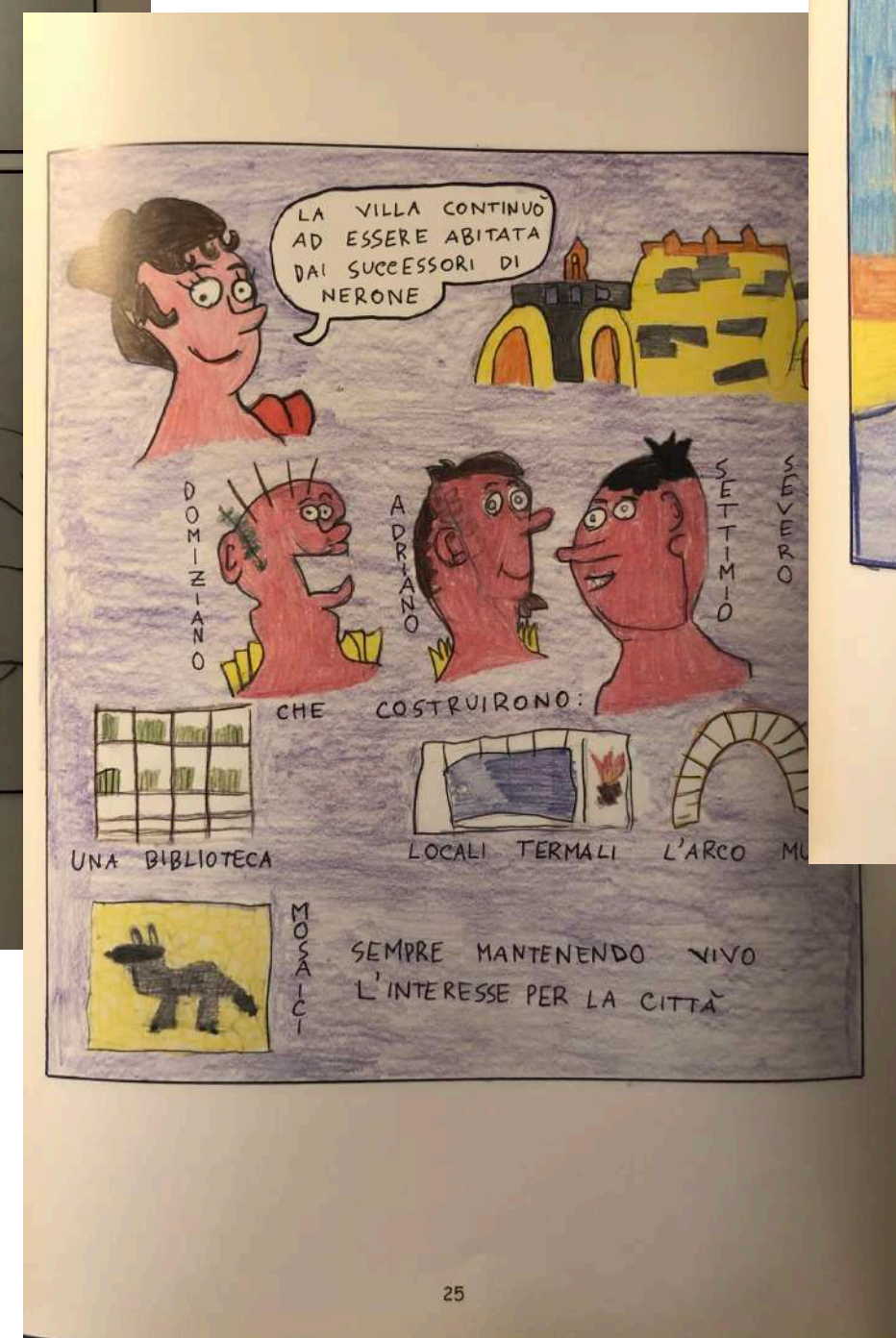
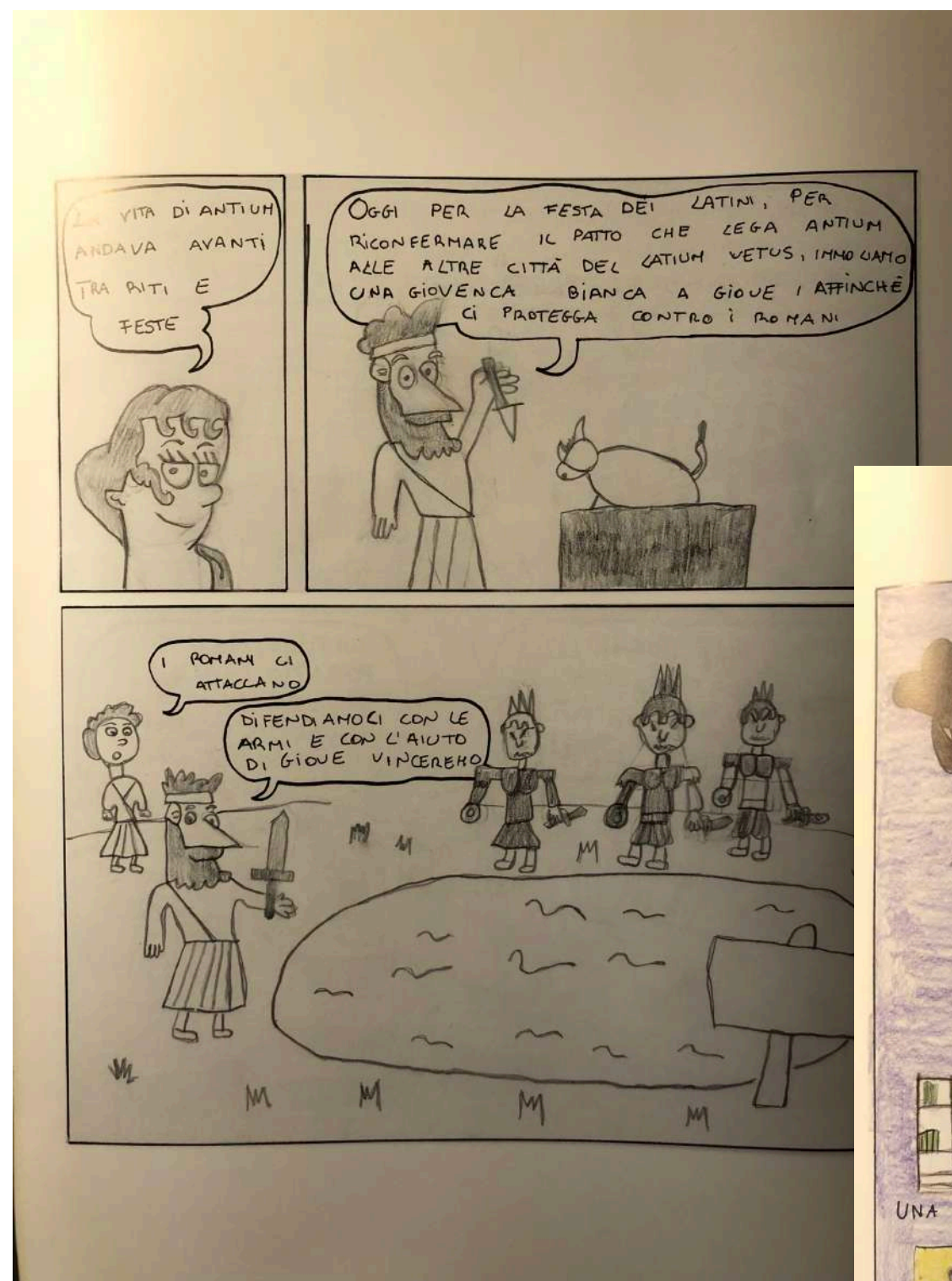



## NARRATIVO

RACCONTA  
UNA STORIA  
VERA O DI  
FANTASIA

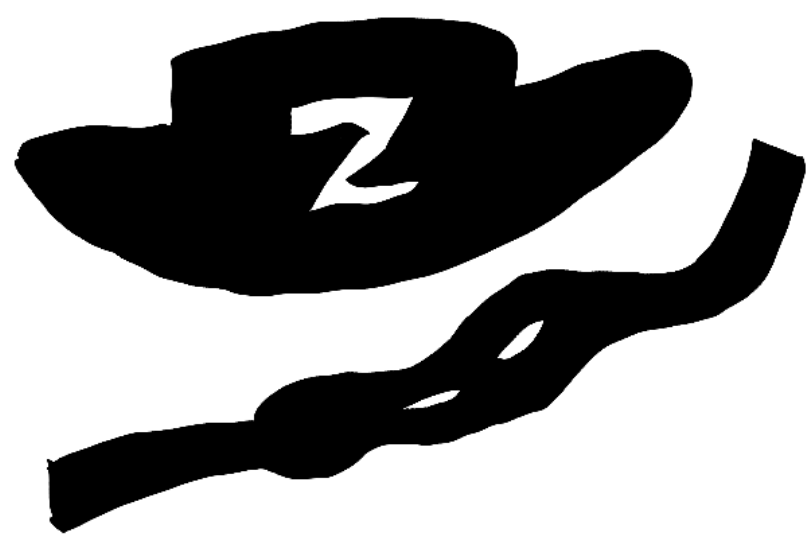

## DESCRITTIVO

DESCRIVE  
PERSONE,  
LUOGHI O  
OGGETTI

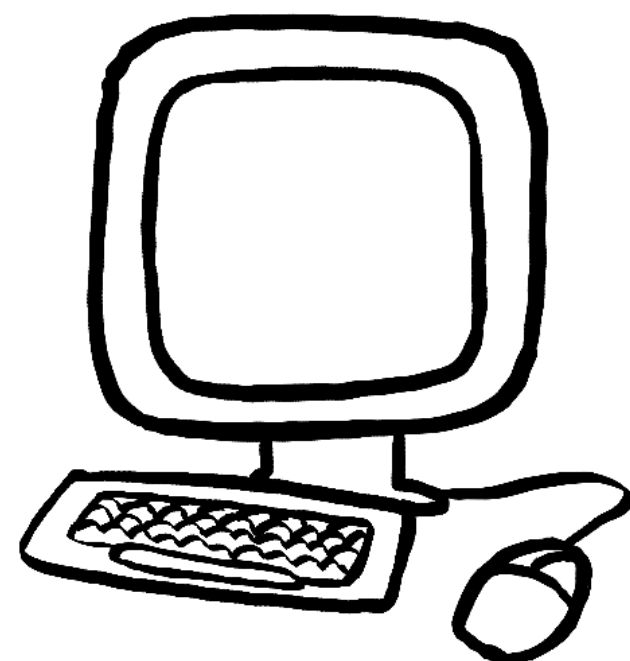

## ARGOMENTATIVO

ESPONE UN  
RAGIONAMENTO  
PER SOSTENERE  
UNA TESI



## INFORMATIVO

PRESENTA  
INFORMAZIONI



## REGOLATIVO

INDICA NORME,  
COMPORAMENTI  
E PROCEDURE

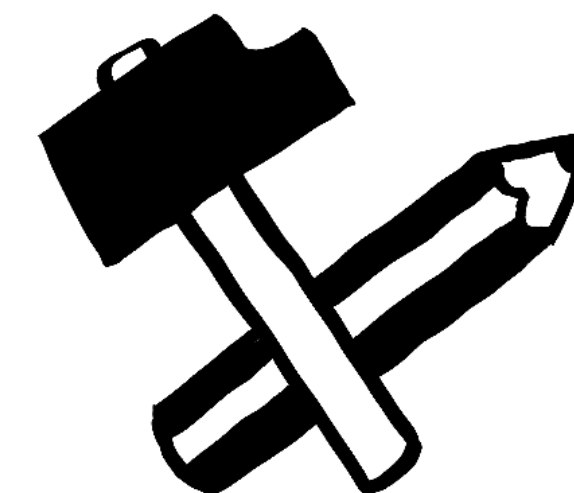

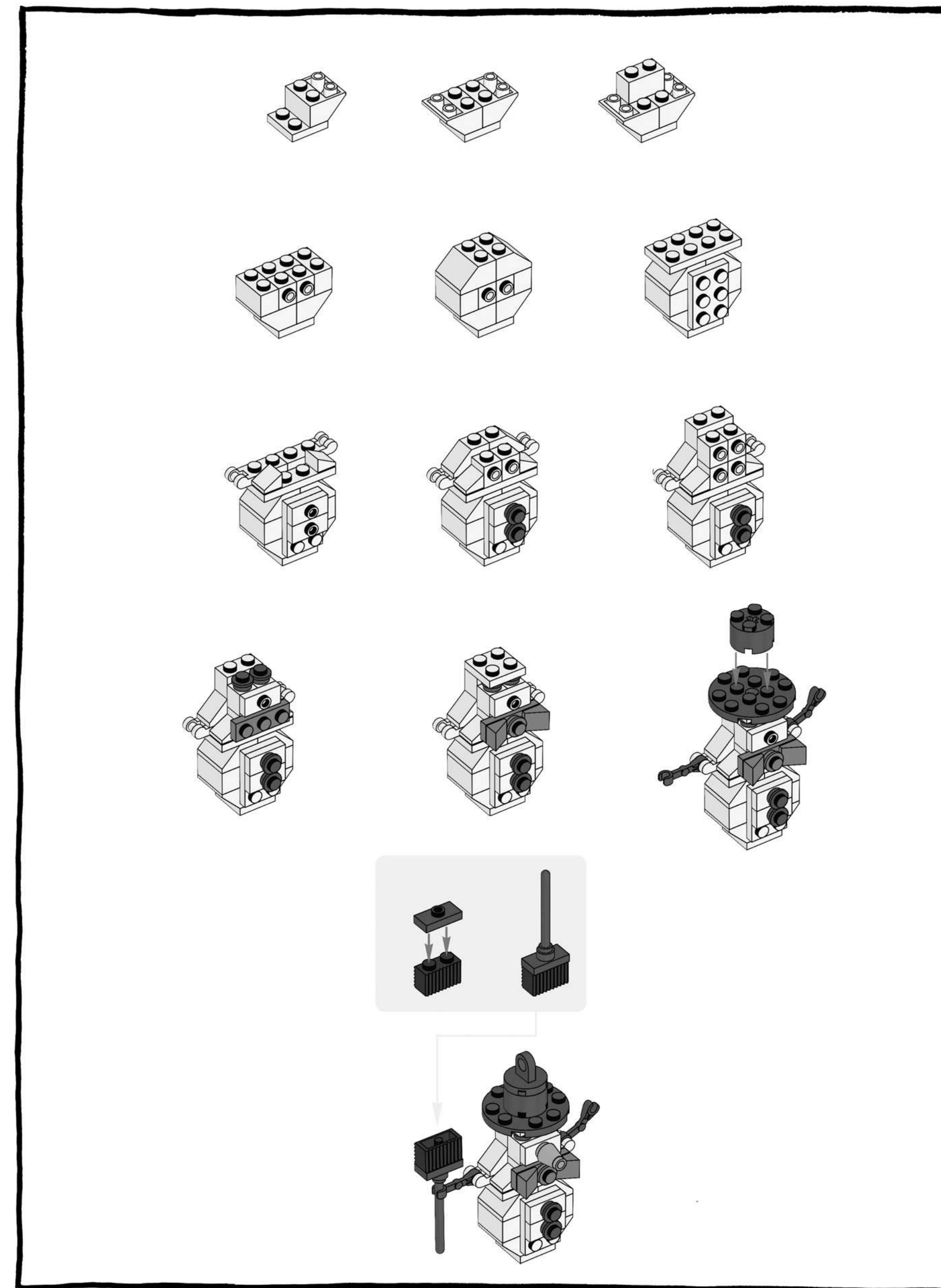

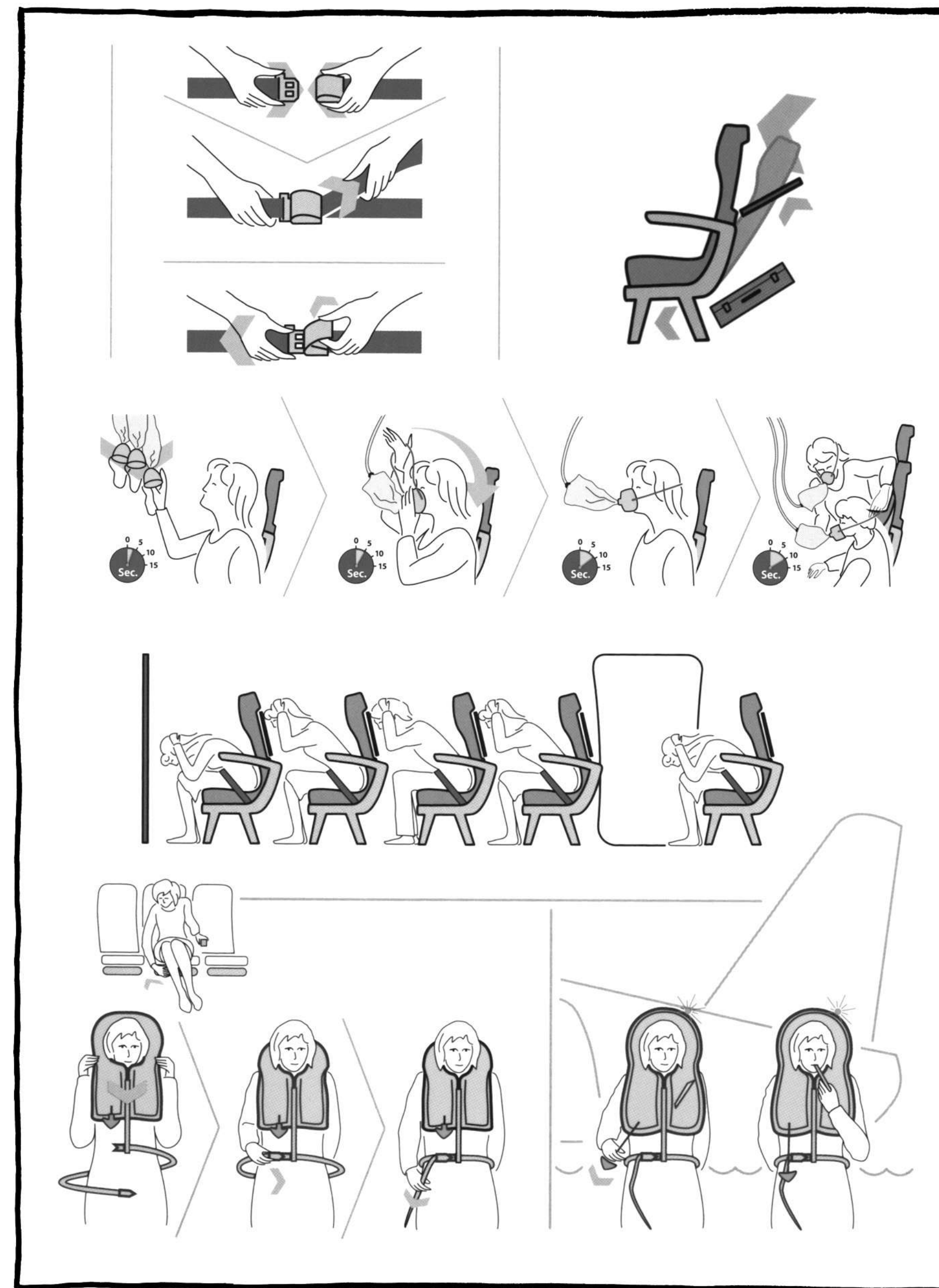

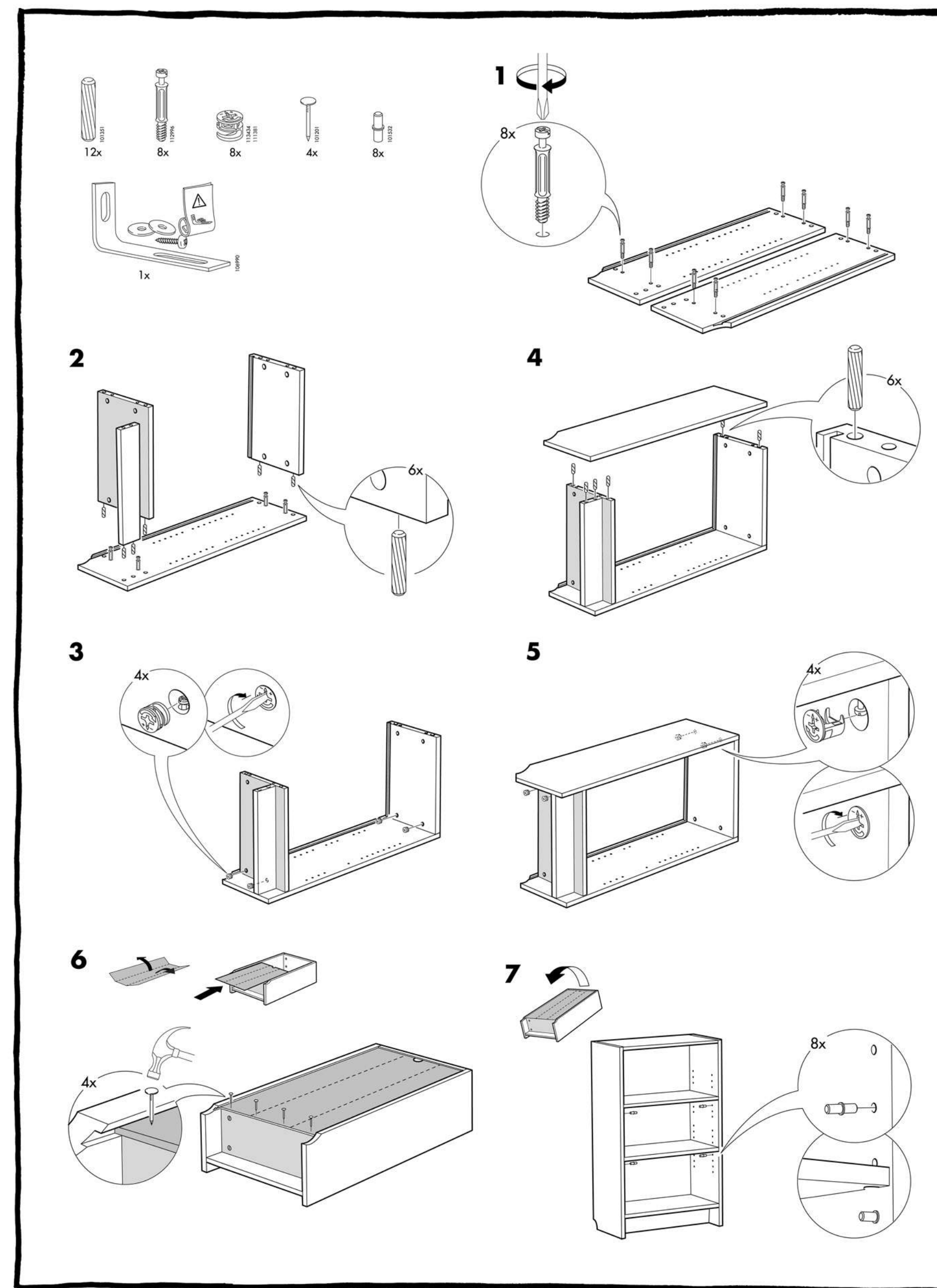

# Le **CINQUE** cose che bisogna sapere sul linguaggio del fumetto

# 1. Chi legge è al centro



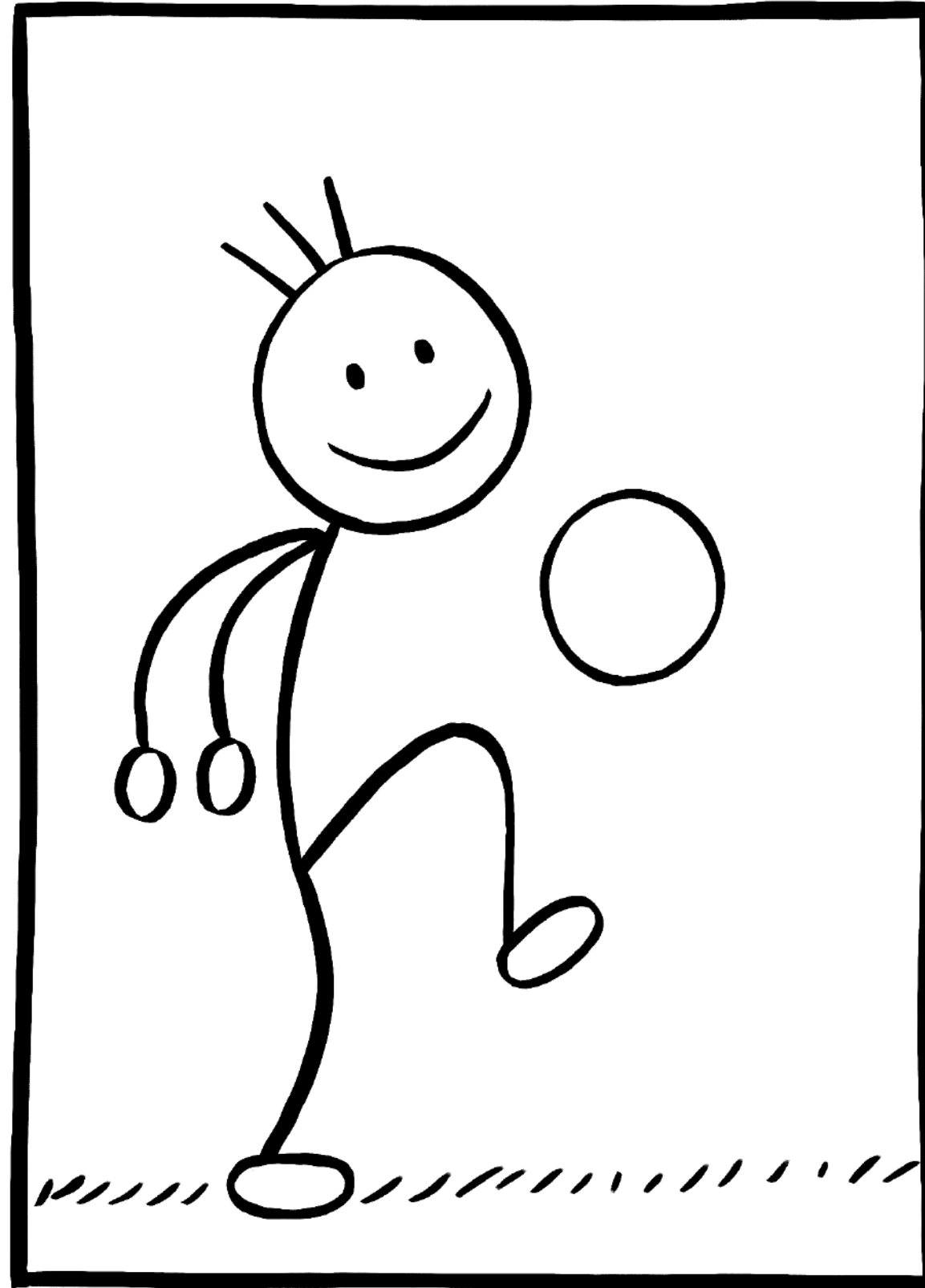

## 2. Lo spazio bianco

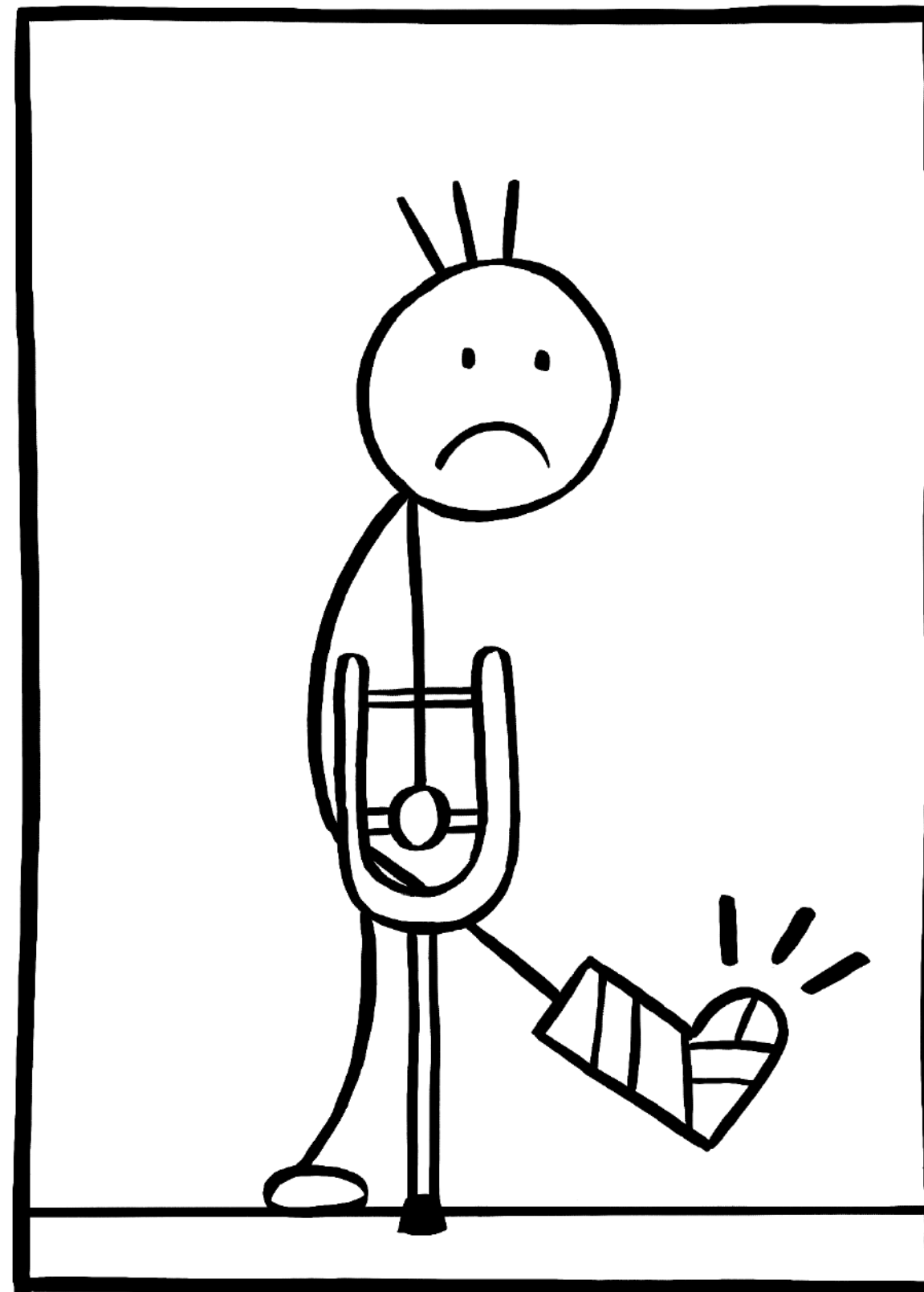
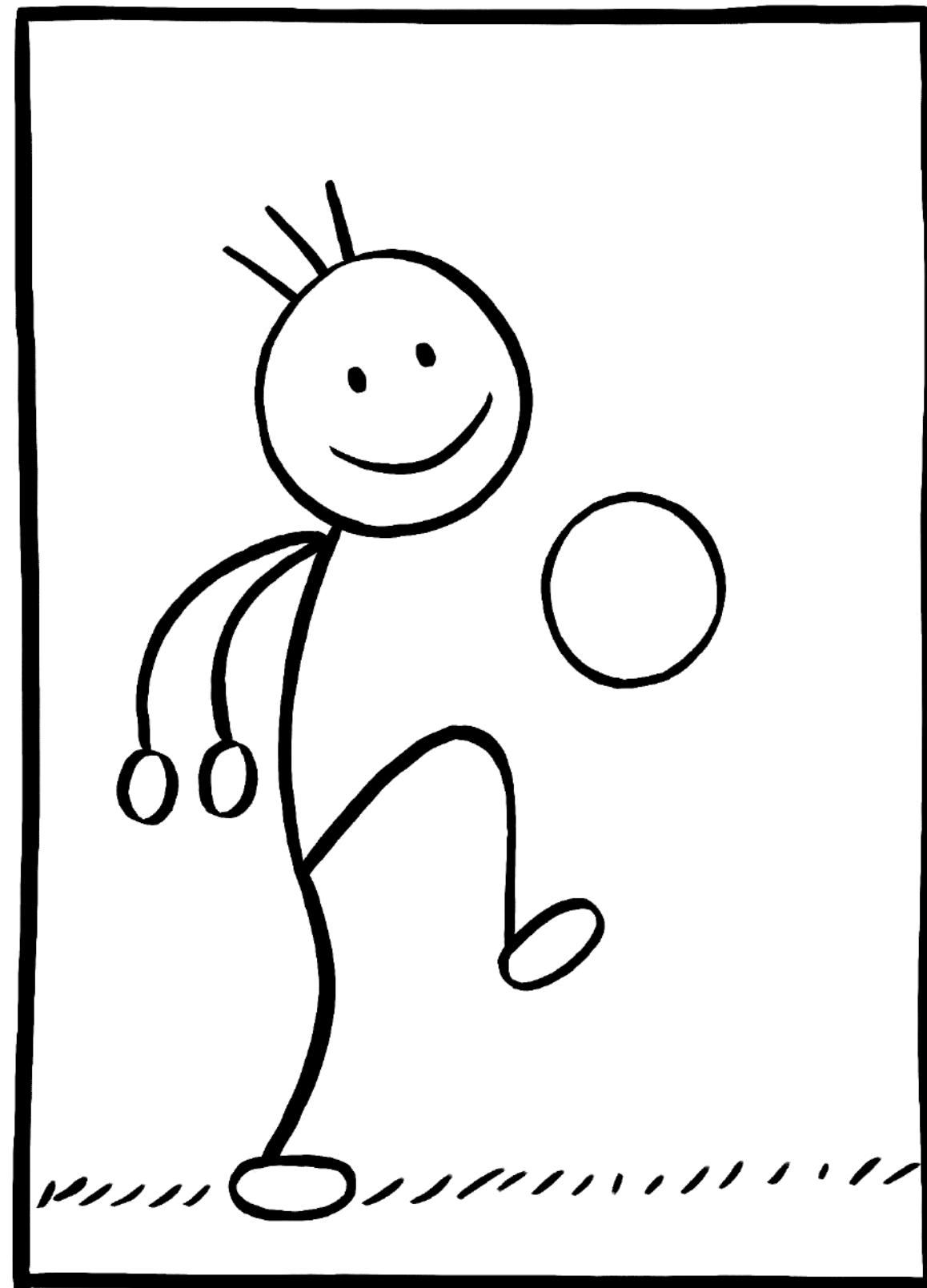



**Lo spazio bianco** deve essere interpretato da chi legge, quindi bisogna dare più elementi possibili per poterlo far riempire da tutti più o meno nello stesso modo.

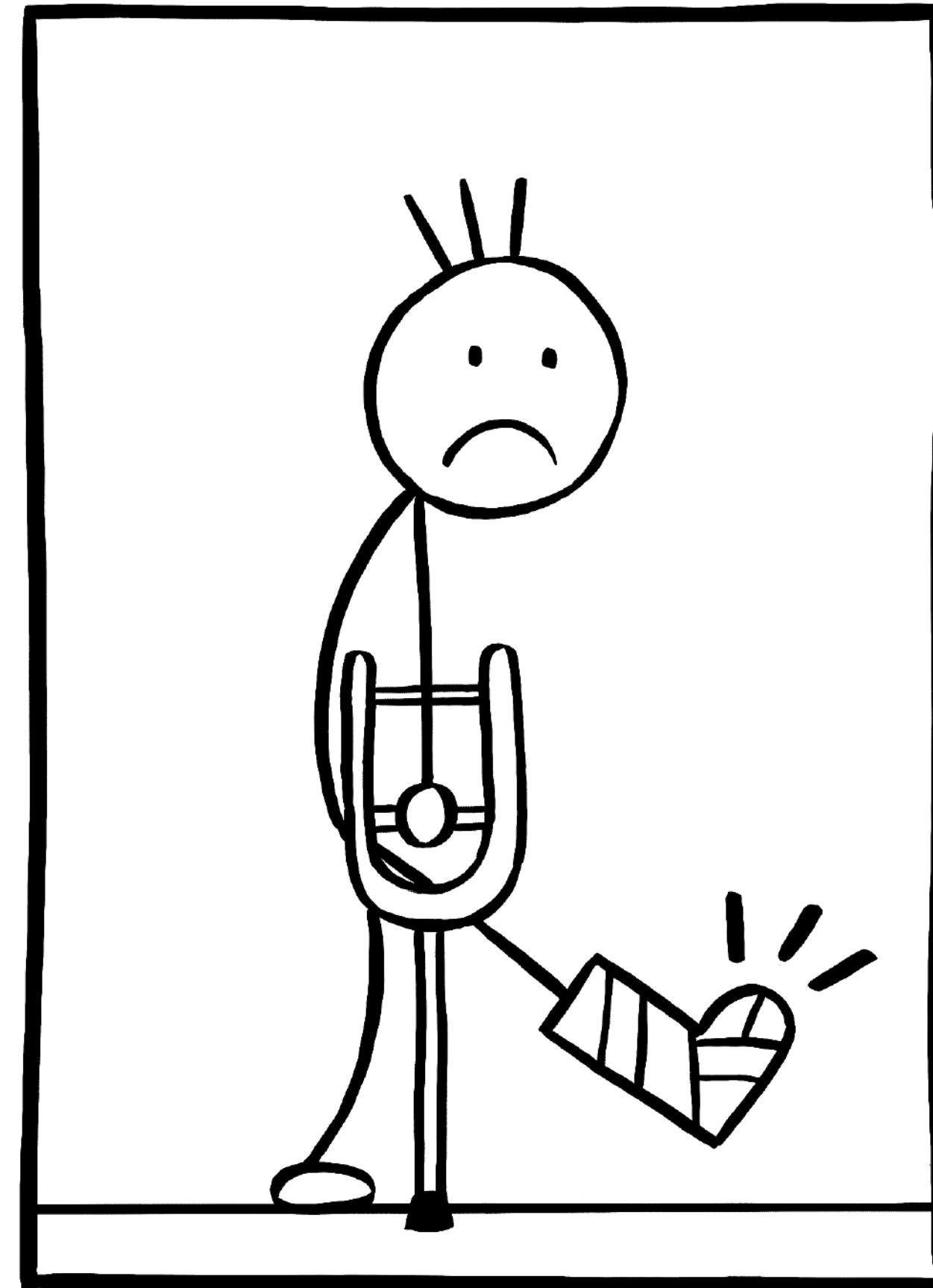
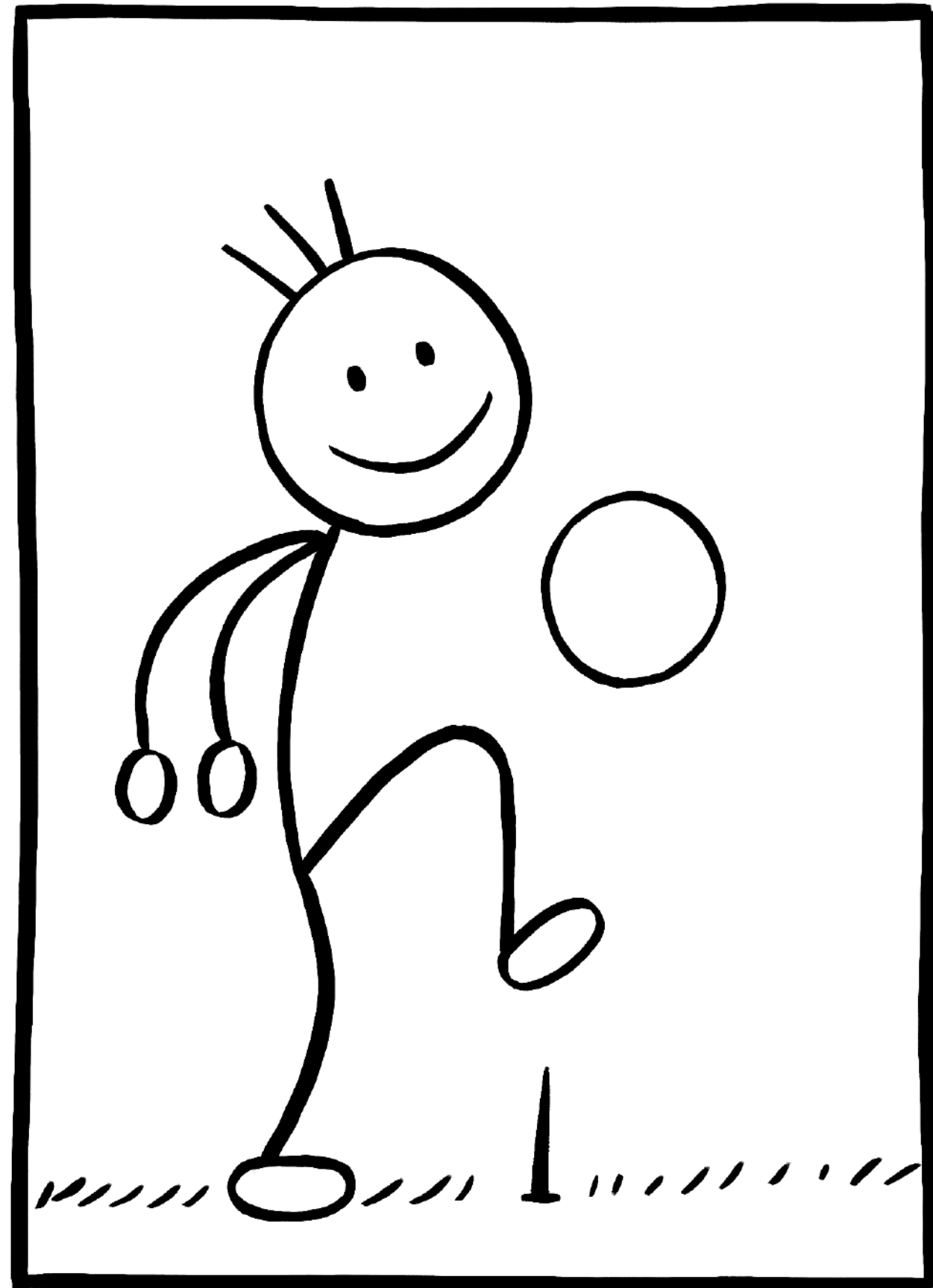

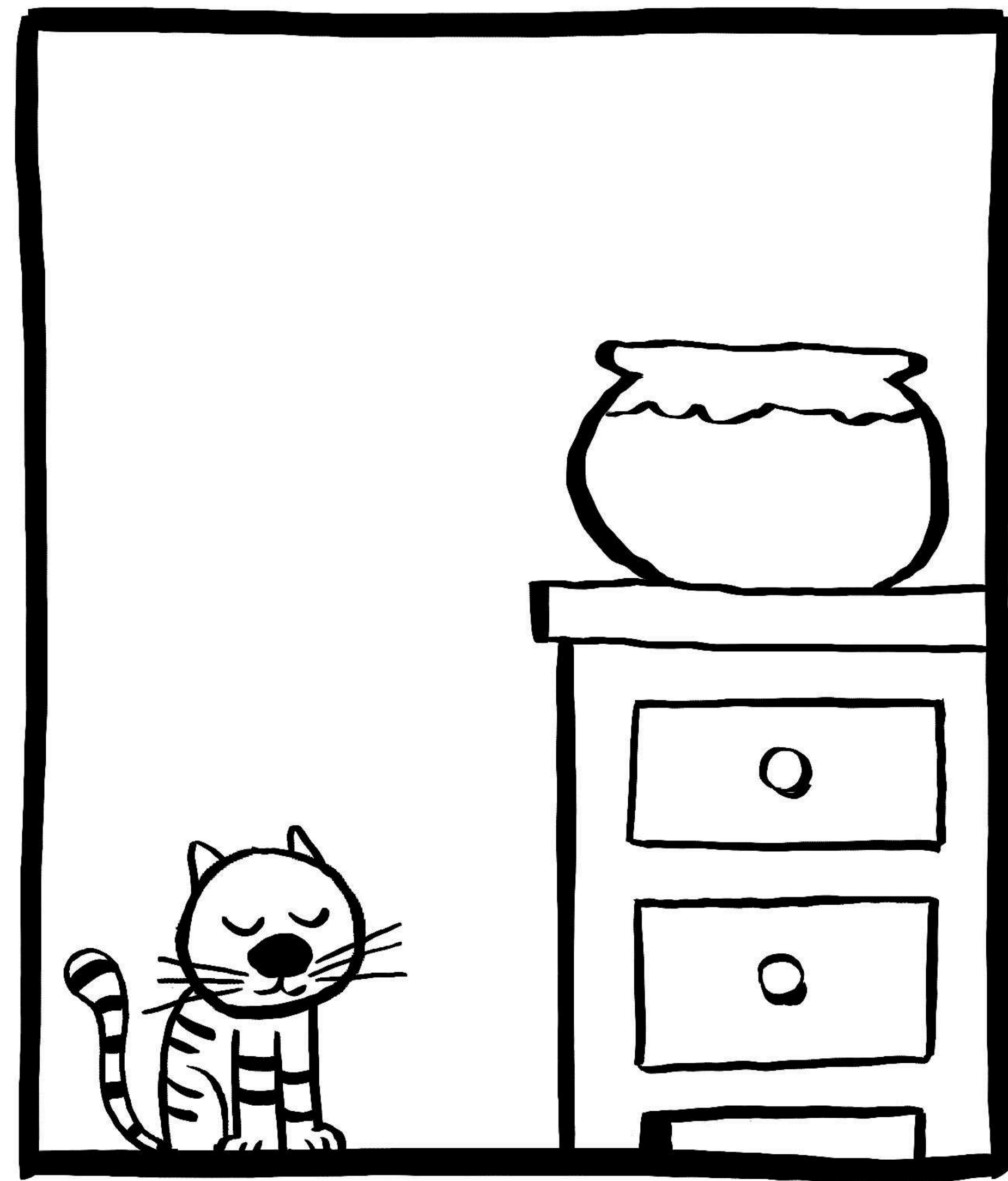
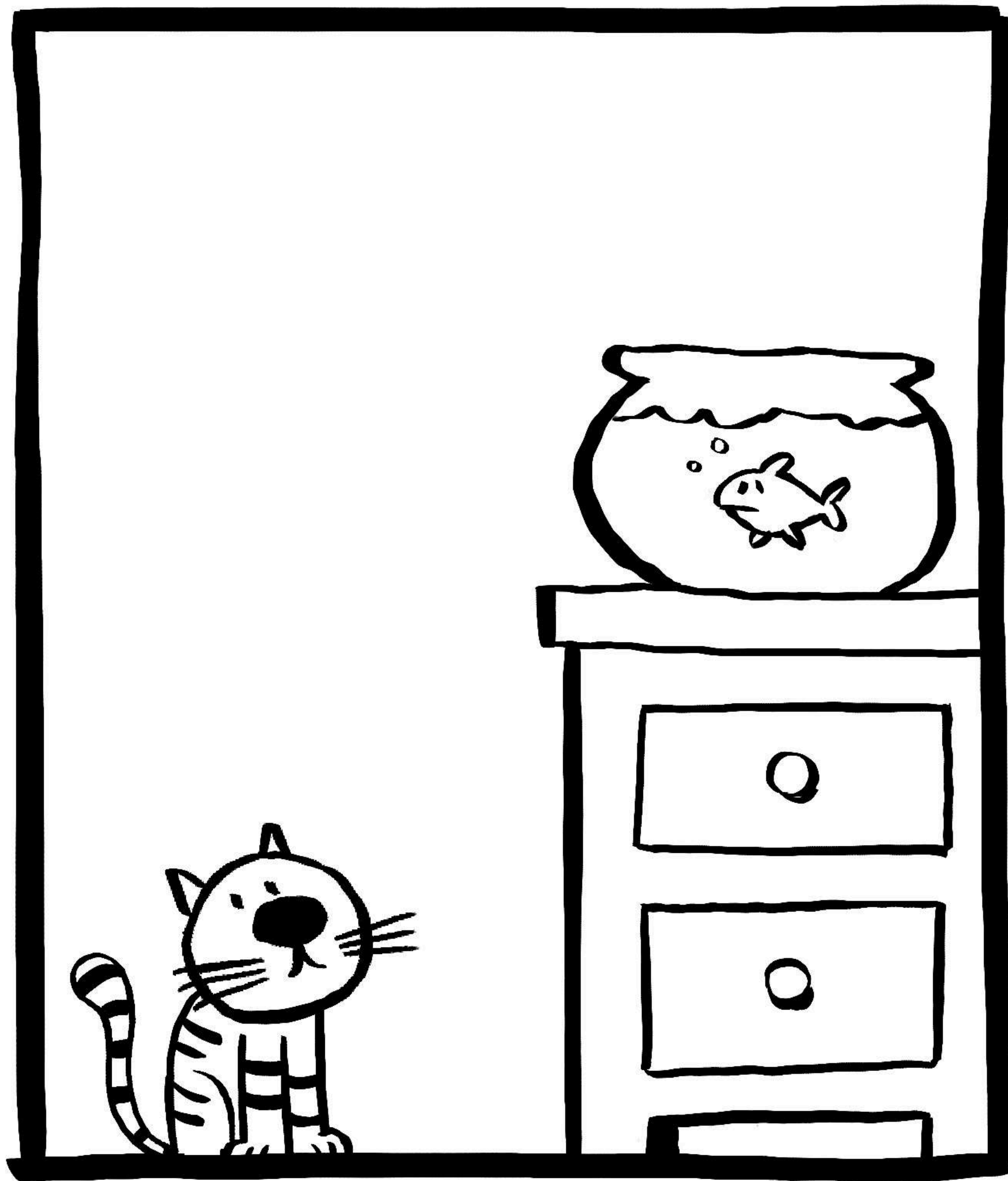

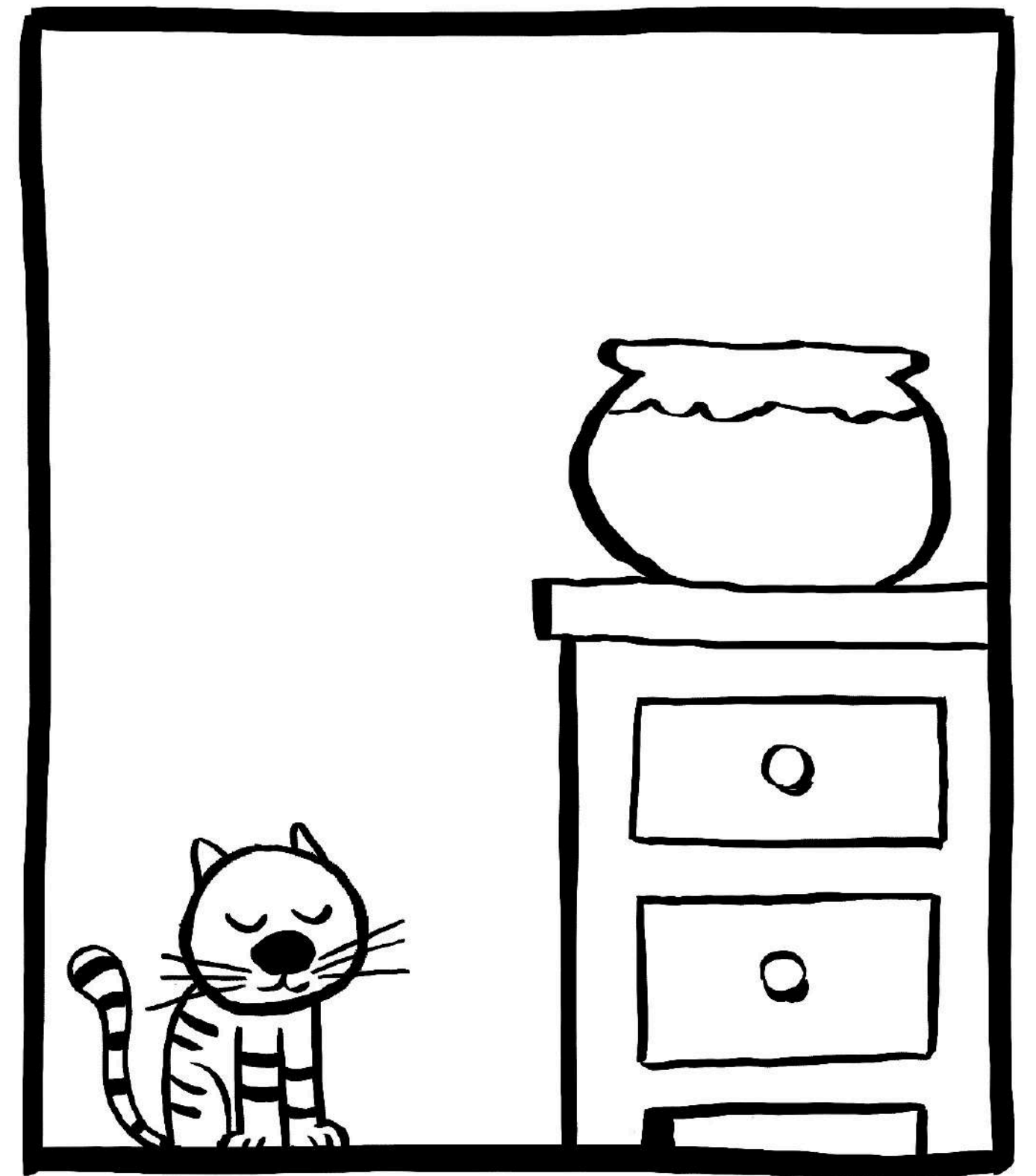
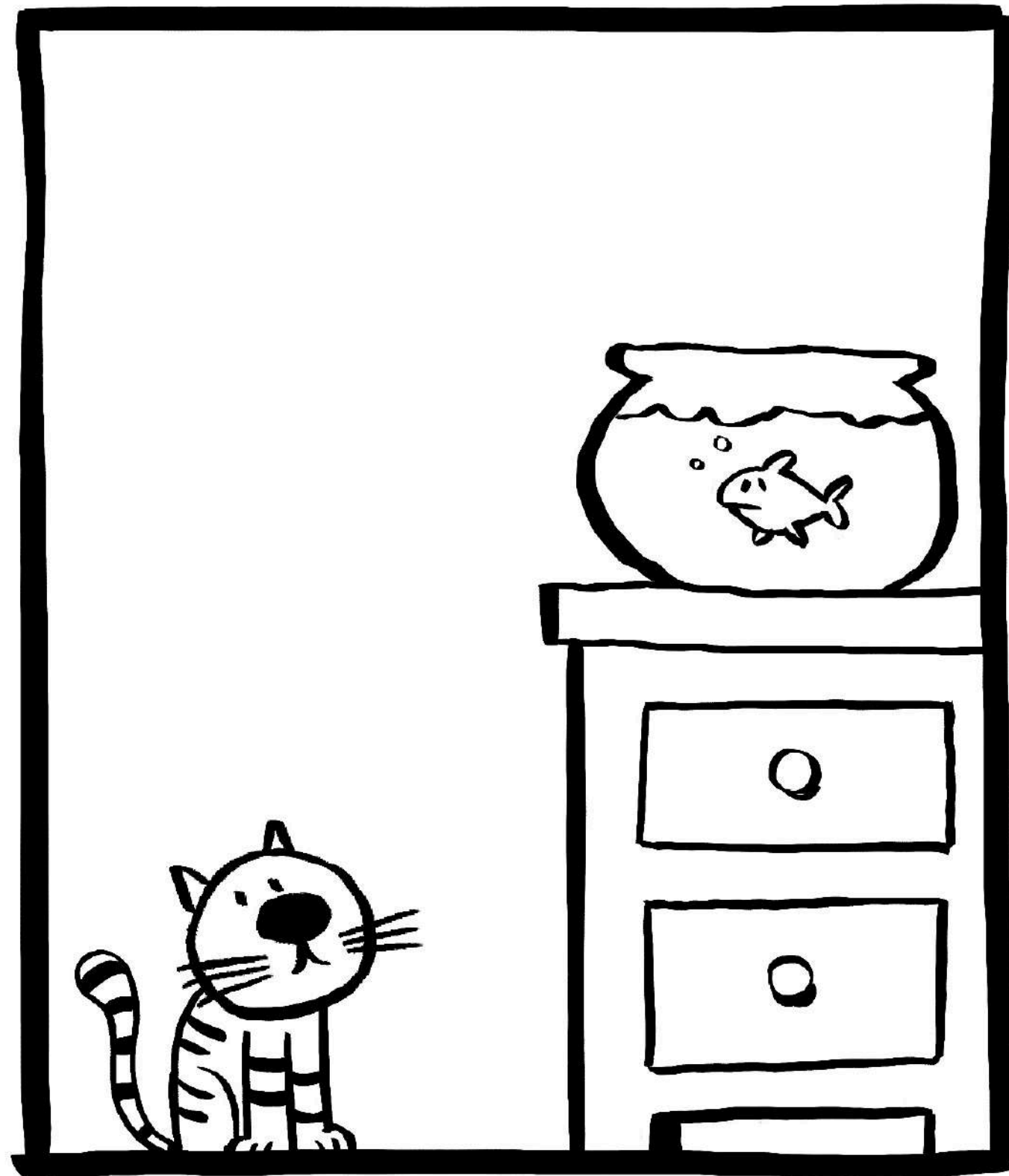



#tuttipossonofarefumetti | [www.gud.it](http://www.gud.it) | [gud@gud.it](mailto:gud@gud.it) | Fb: [gudcomics](https://www.facebook.com/gudcomics) | Tw e Ig: [@guddaman](https://www.instagram.com/guddaman)

**3. Il senso di lettura** del fumetto in occidente è dall'alto in basso e da sinistra verso destra. Quindi se un testo o un evento va letto per primo deve essere più in alto e/o più a sinistra di quello che dovrà essere letto successivamente.

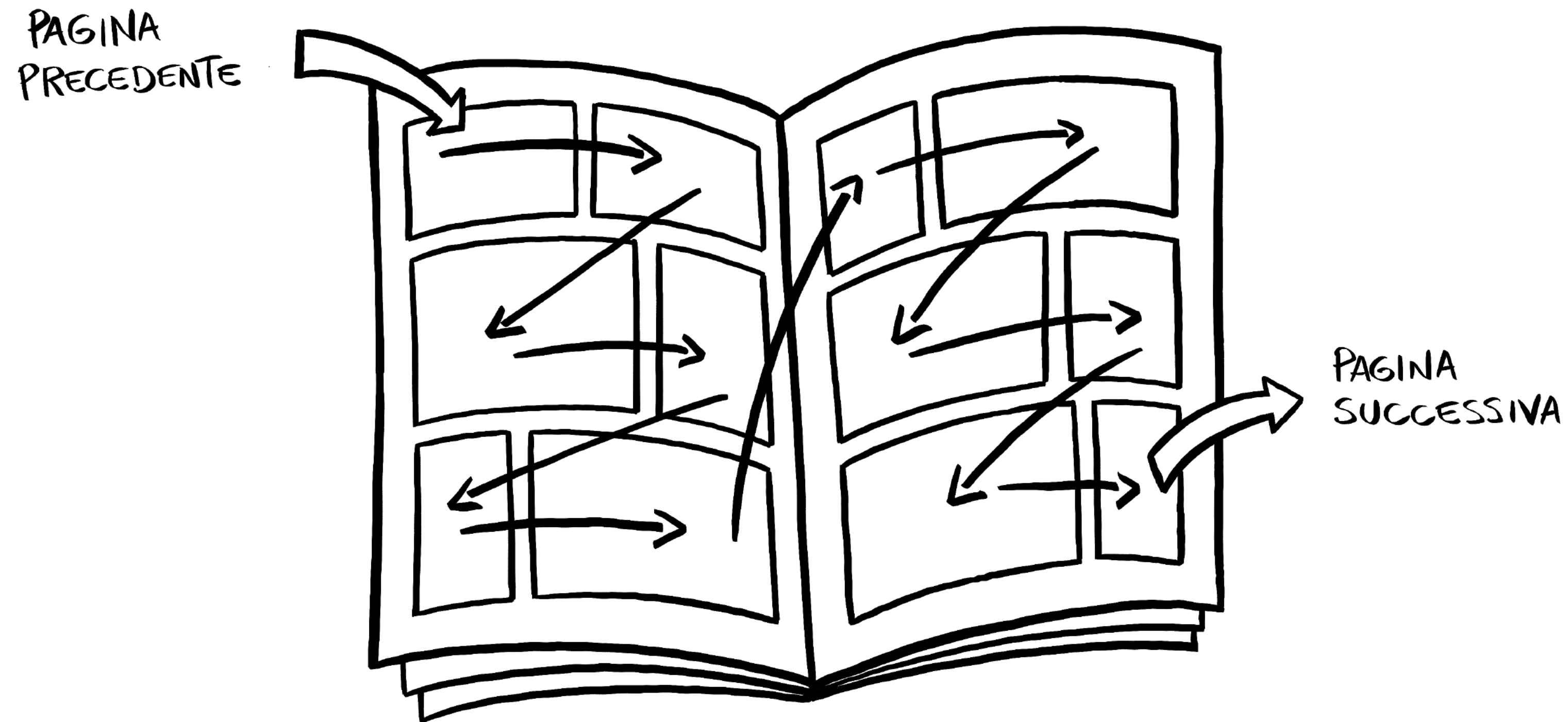

**4. I personaggi devono essere sempre riconoscibili.** Per questo vengono spesso creati su forme geometriche, oggetti, frutta, verdura e animali.

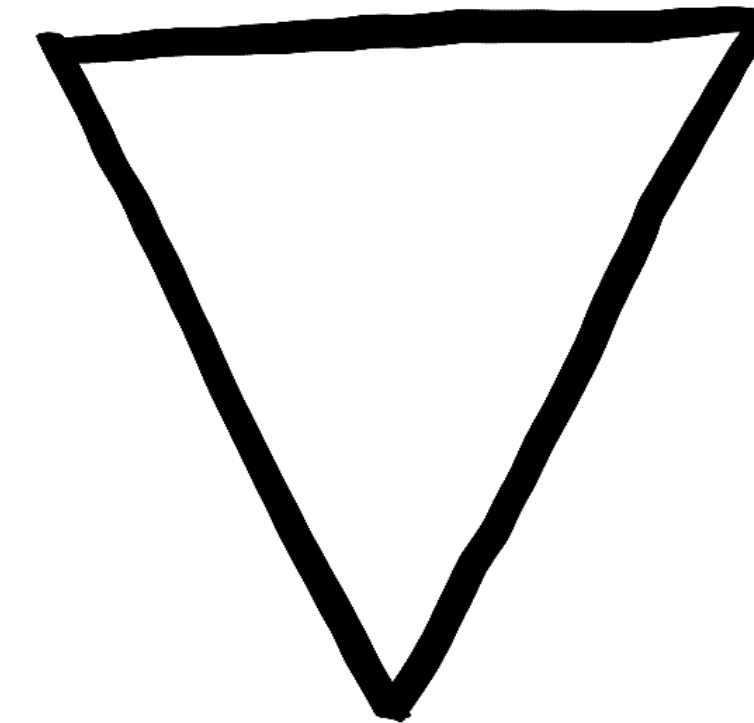
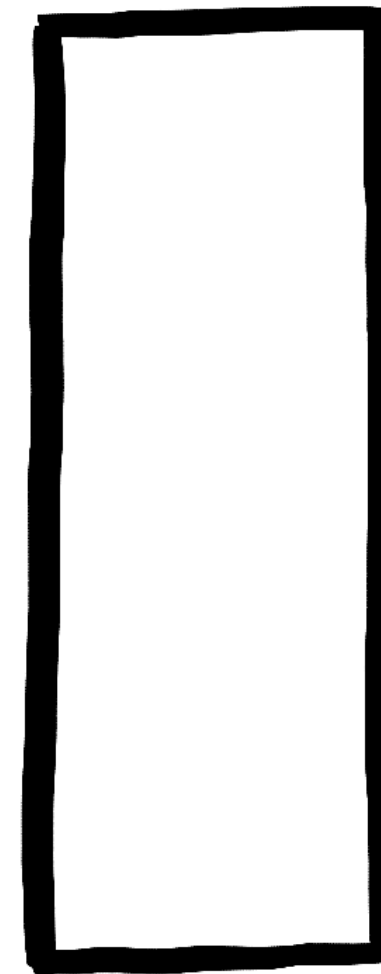
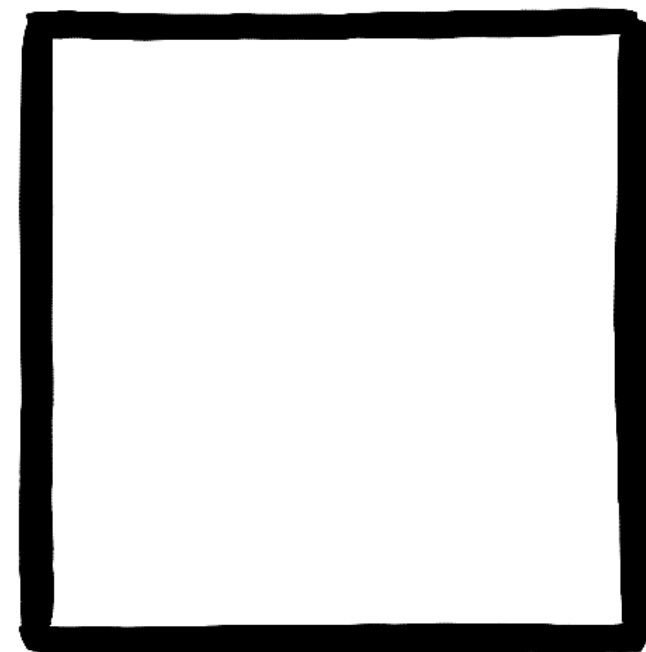
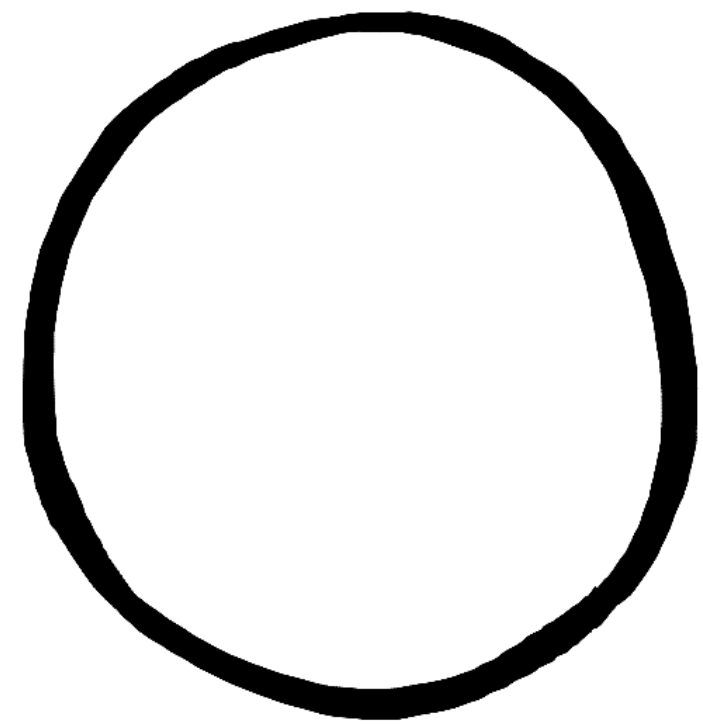

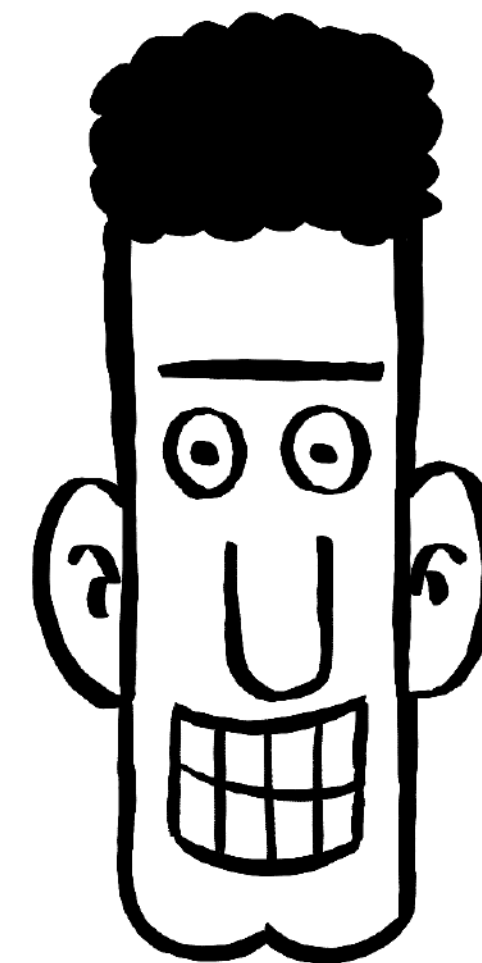
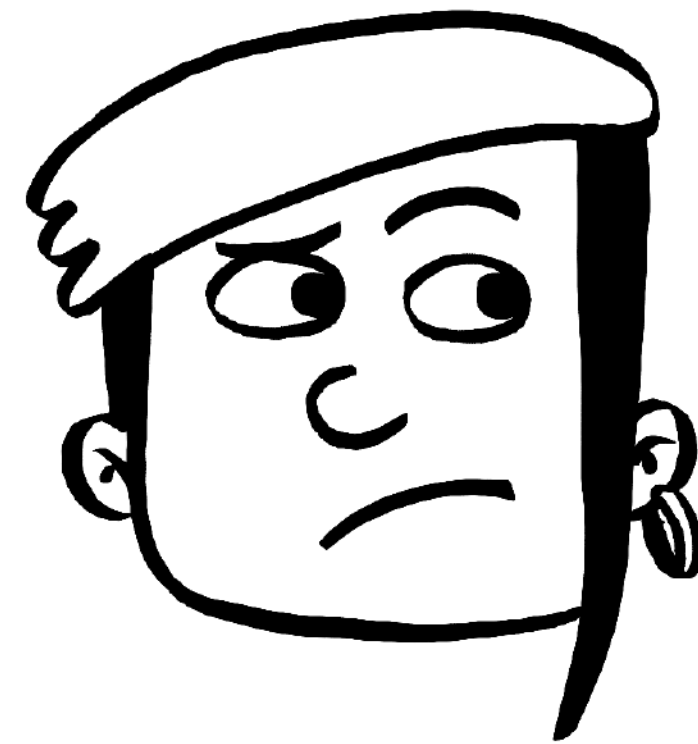
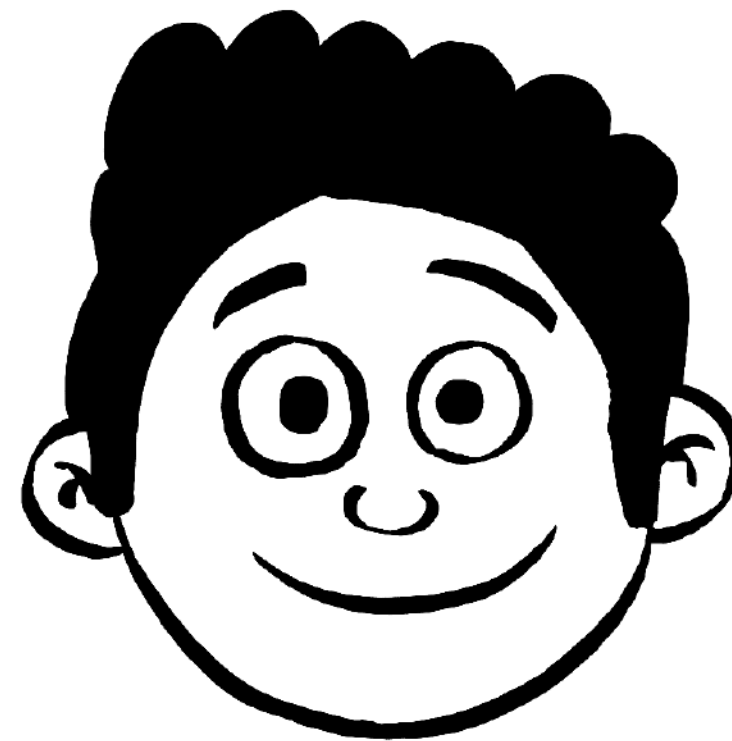
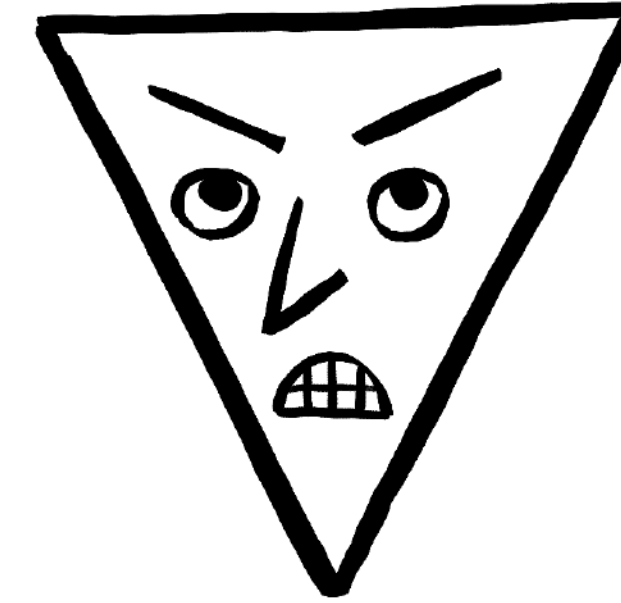
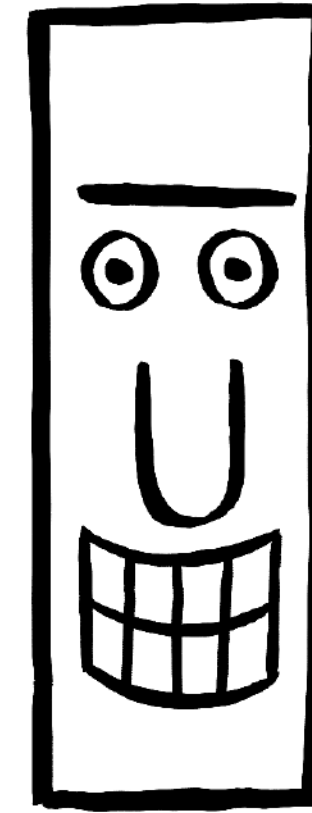
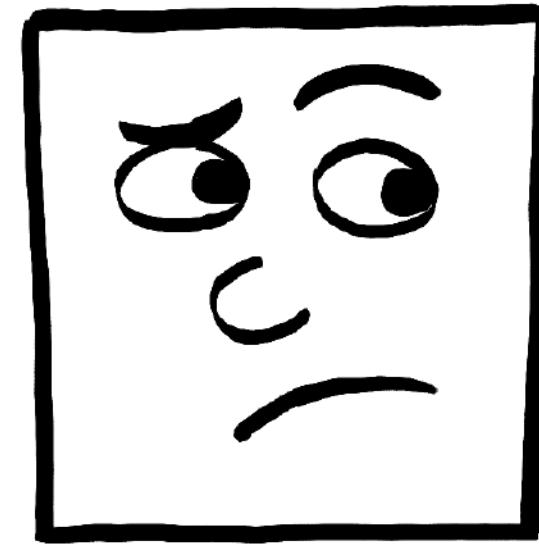
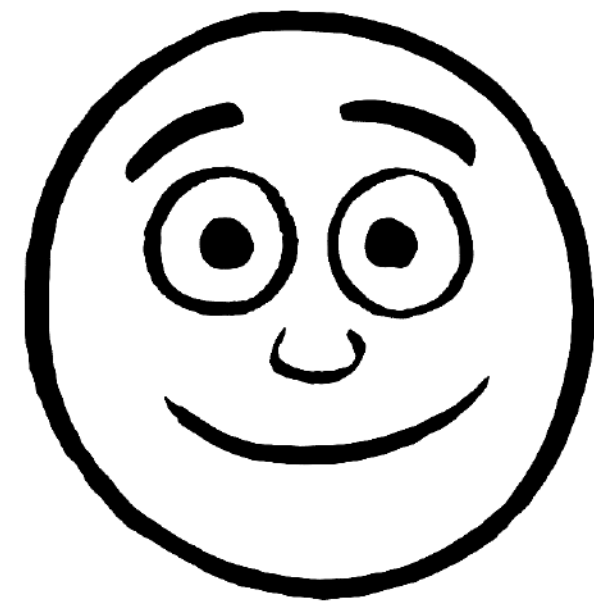

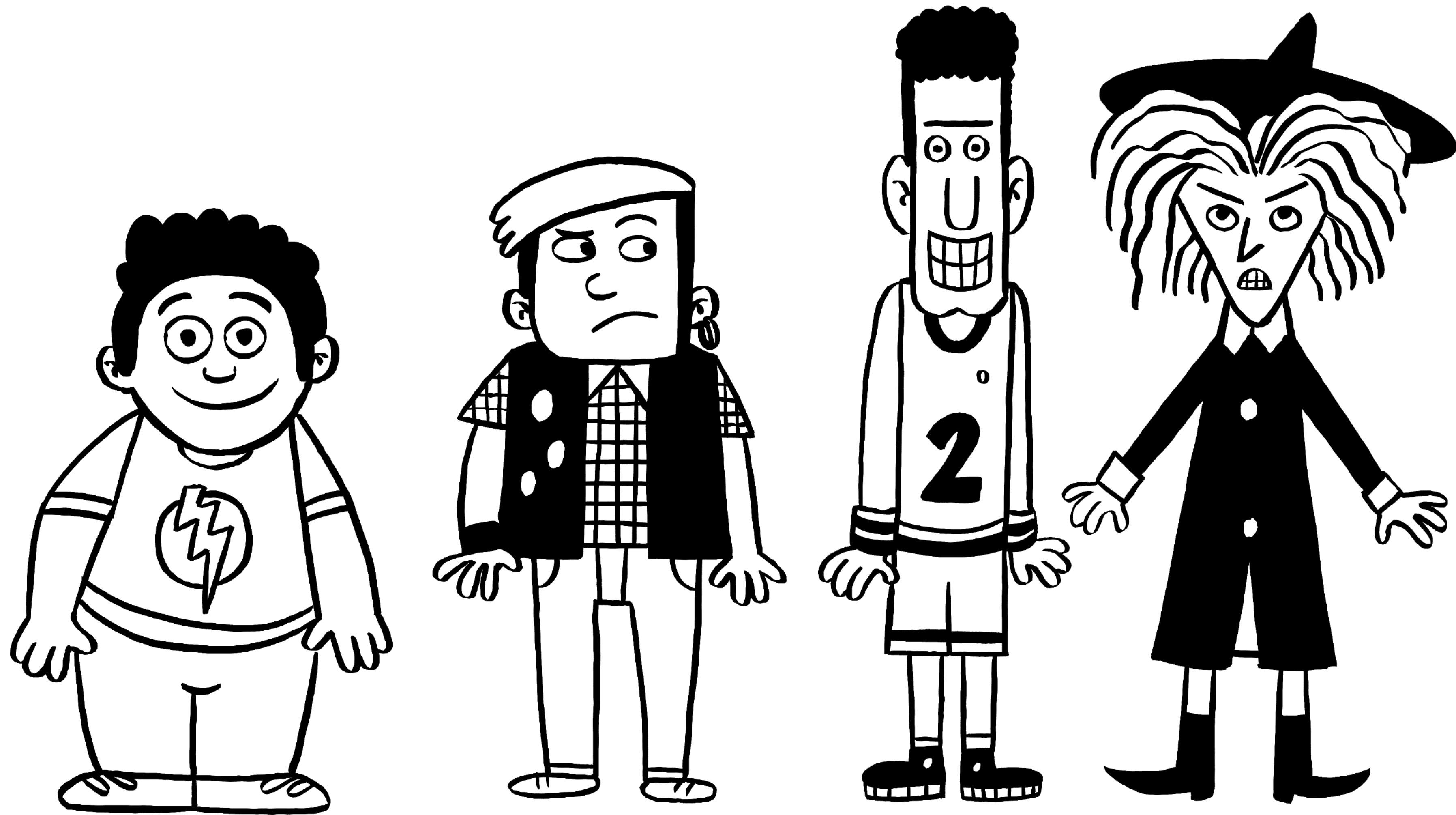



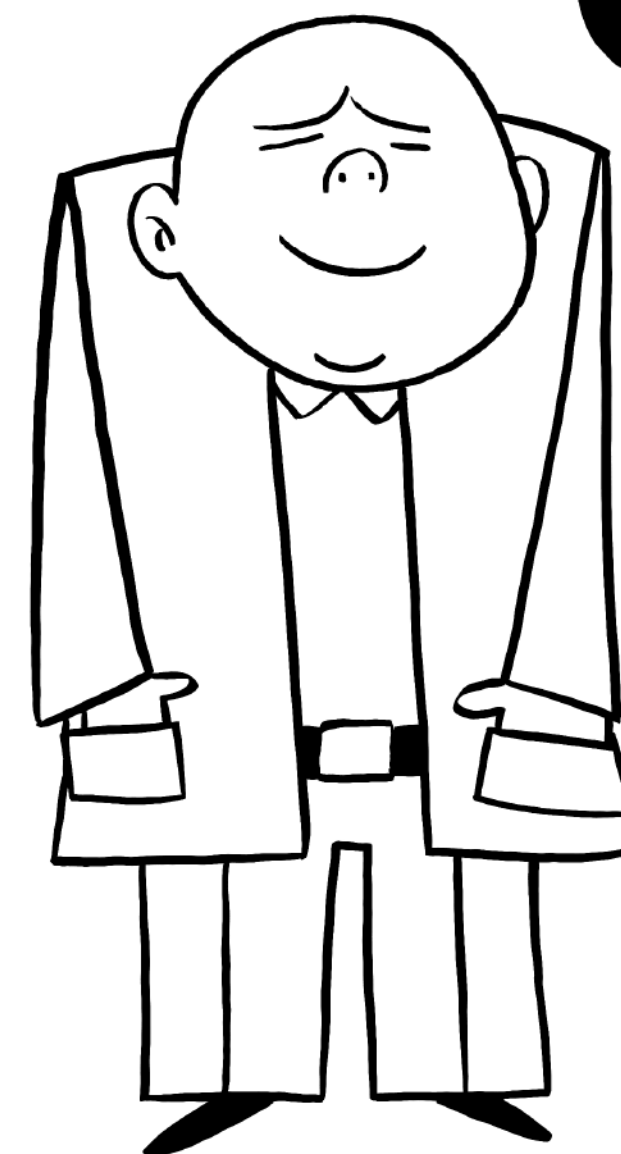
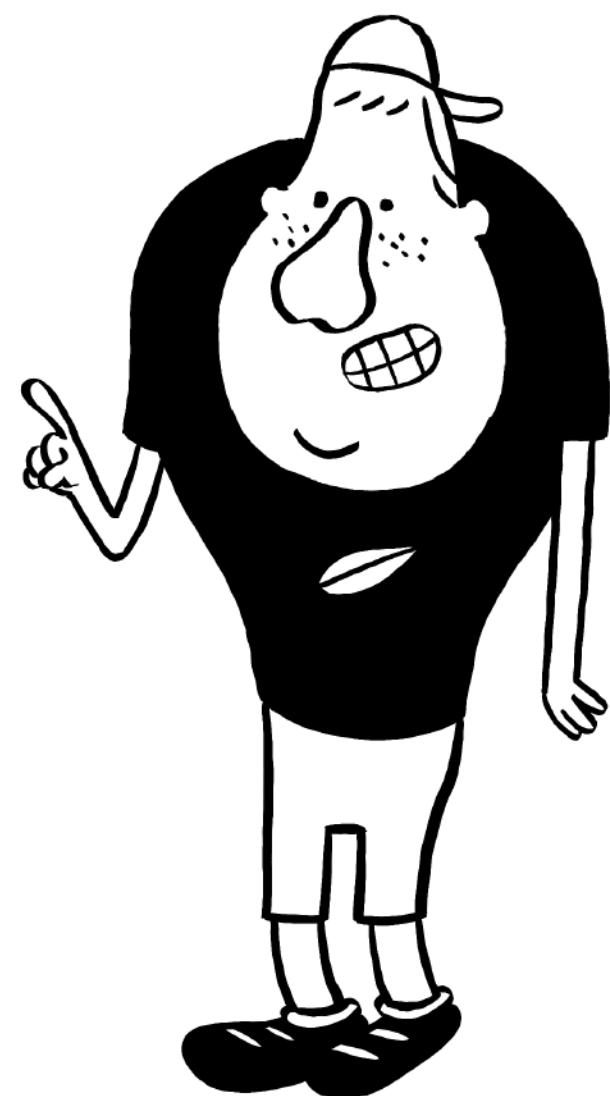
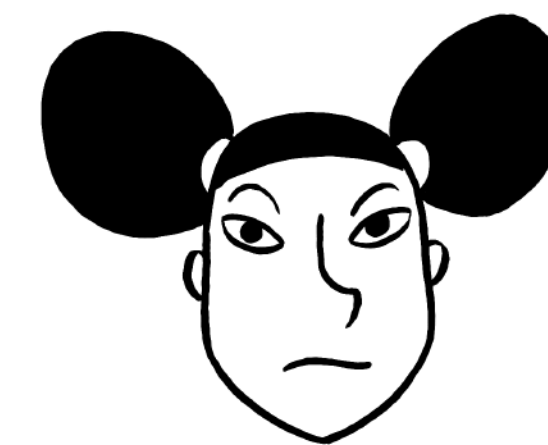
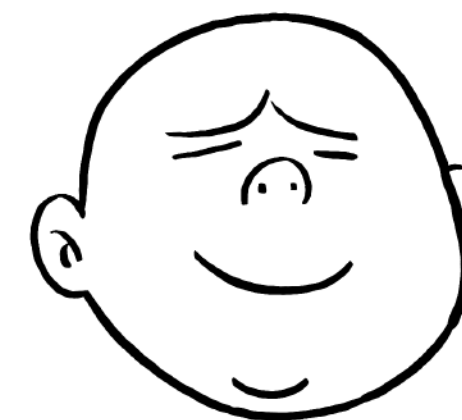
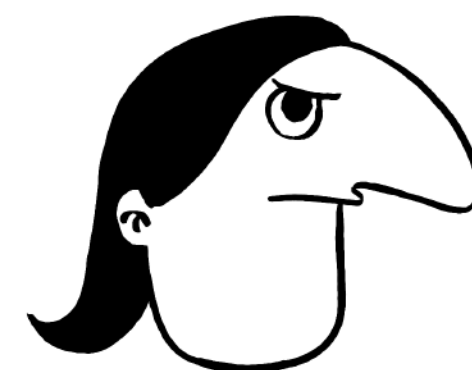
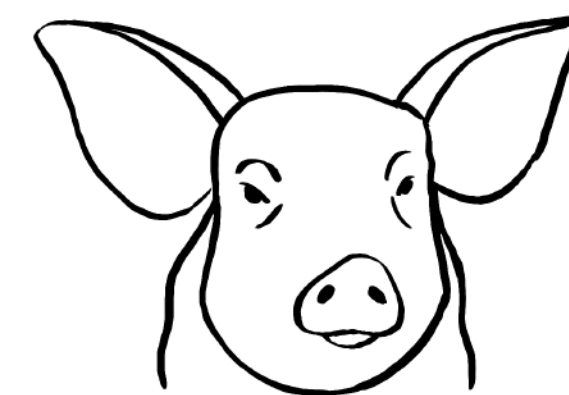
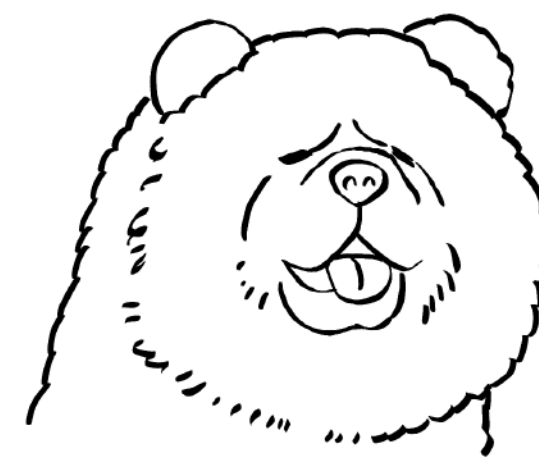
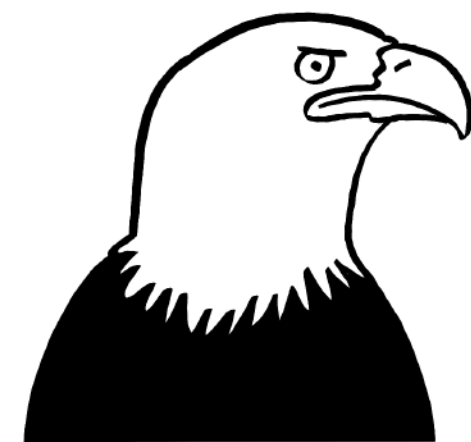
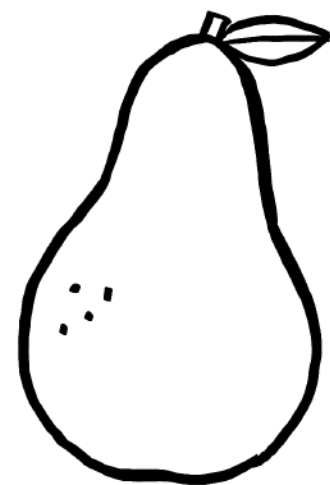
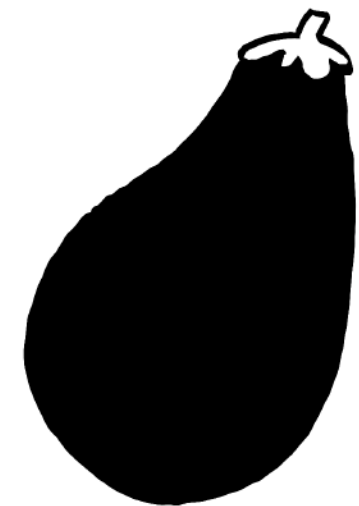
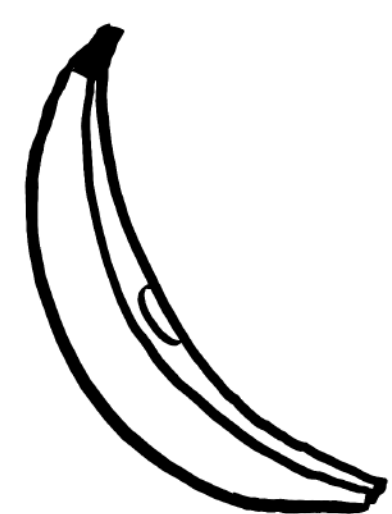

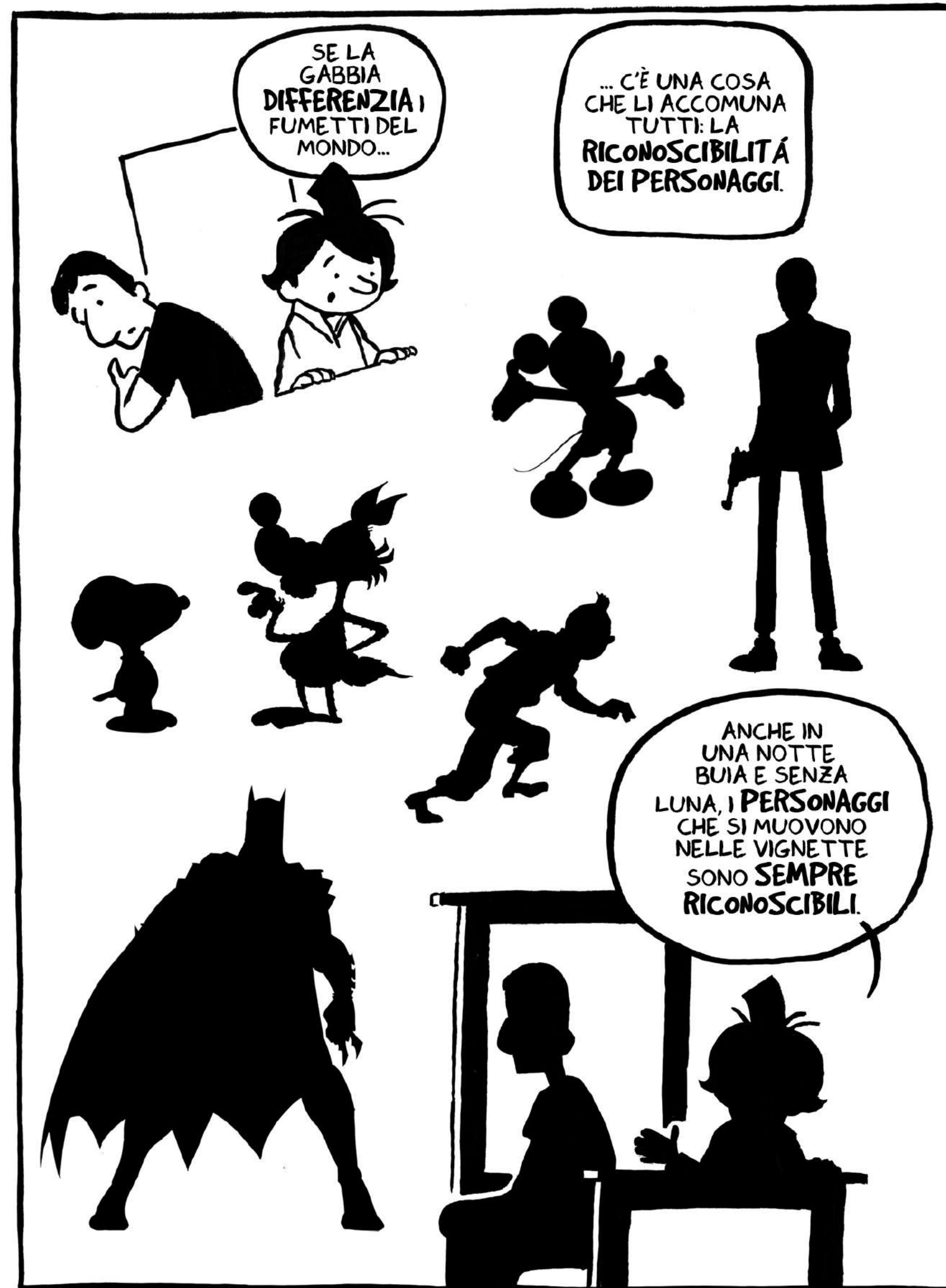

**5. I testi devono essere leggibili**, preferibilmente in STAMPATO MAIUSCOLO, e devono avere un po' di spazio tra loro e il bordo del balloon (la nuvoletta da cui parlano i personaggi) e delle didascalie.

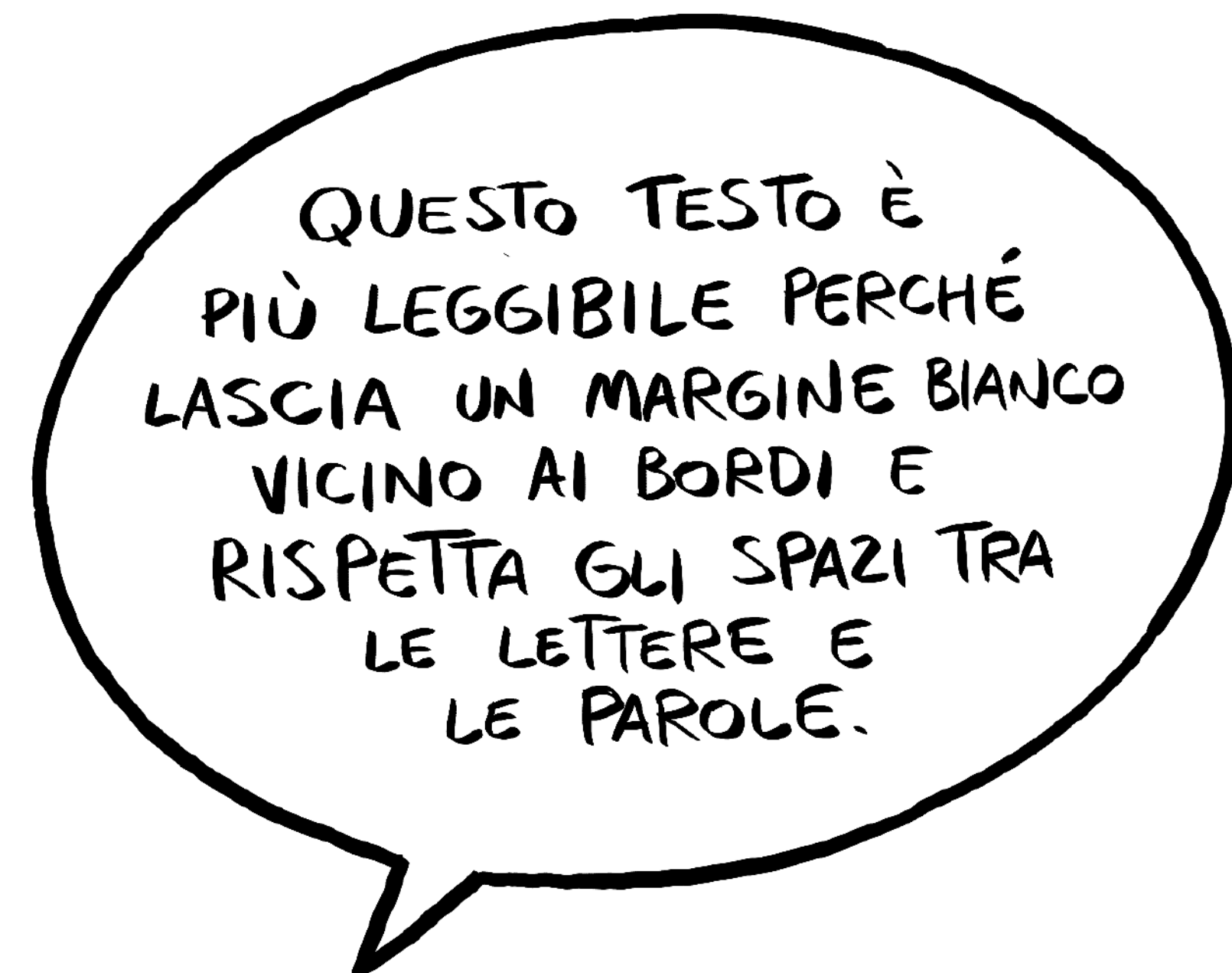
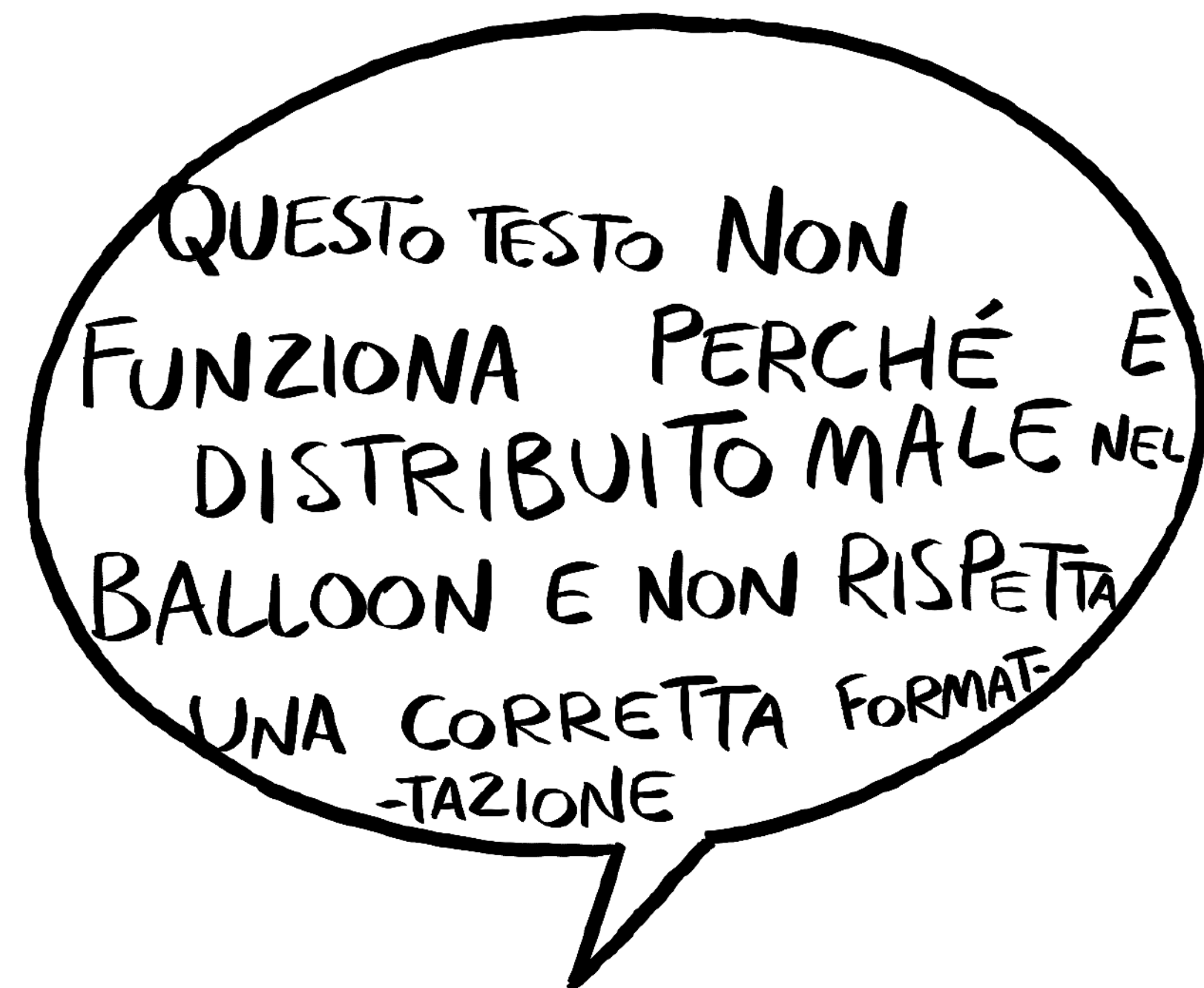



ALTEZZA

BANG

SUONO ACUTO

BANG

SUONO GRAVE

INTENSITÀ

BONG

VOLUME ALTO

BONG

VOLUME BASSO

DURATA

CRAAAAACK

SUONO LUNGO

CRACK

SUONO BREVE

# 6\*. Le competenze che occorrono per fare fumetti

*\* Lo so, avevo detto 5*

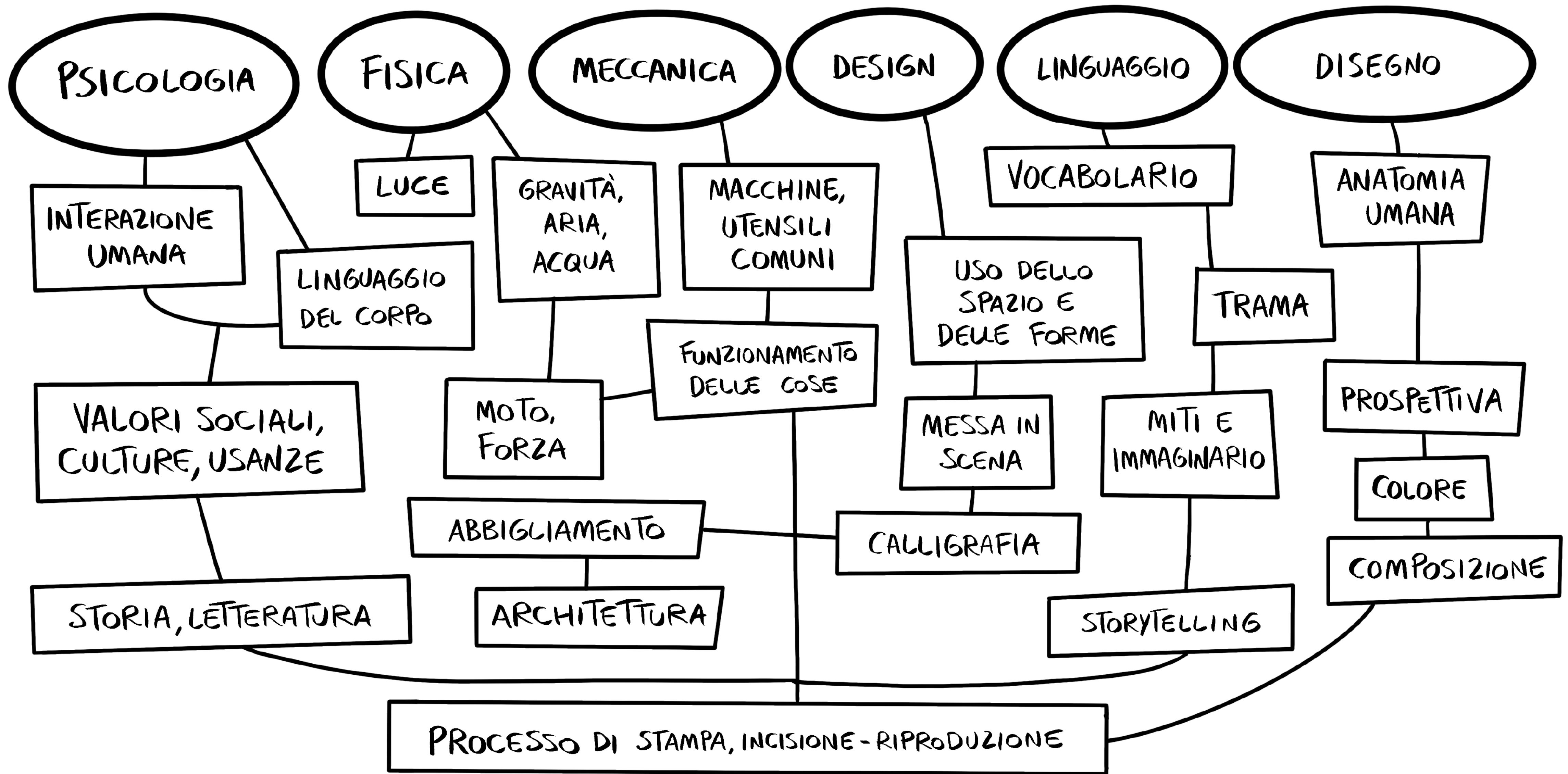

# Come nasce un fumetto?



**Si dice fumetto, manga o graphic  
novel?**

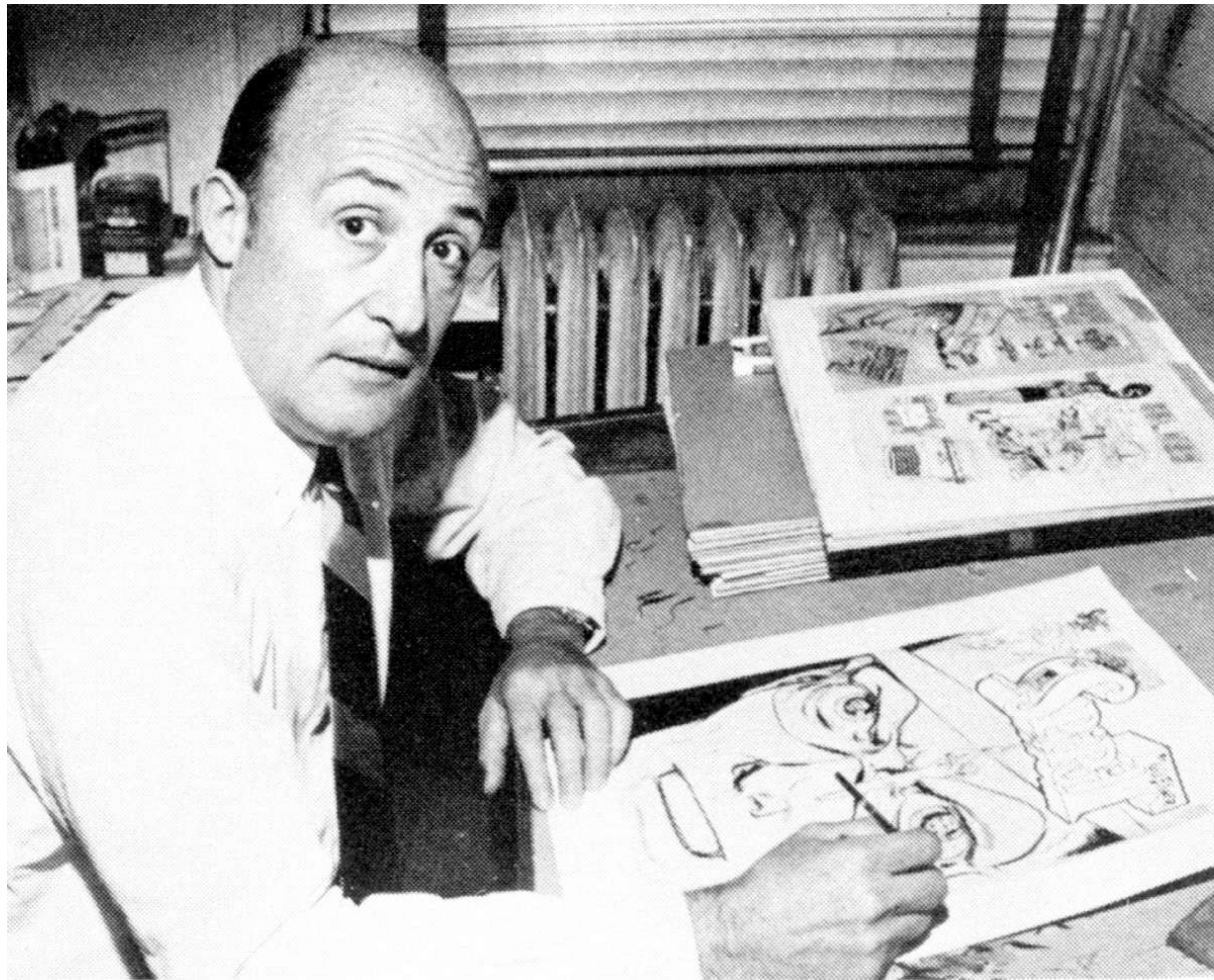

#tuttipossonofarefumetti | [www.gud.it](http://www.gud.it) | [gud@gud.it](mailto:gud@gud.it) | Fb: [gudcomics](https://www.facebook.com/gudcomics) | Tw e Ig: [@guddaman](https://www.instagram.com/guddaman)



PER MOLTO TEMPO LE STORIE NEL FUMETTO HANNO AVUTO LA SOLA FUNZIONE DI INTRATTENERE IL LETTORE.

NEGLI ULTIMI ANNI INVECE CERCANO DI TRASMETTERE QUALCOSA IN PIÙ. FANNO **EMOZIONARE, PENSARE E CONOSCERE** ALTRE REALTÀ.

STA PARLANDO DEI **GRAPHIC NOVEL**?

ANCHE.



LE STORIE A FUMETTI INSERITE IN UN **CONTESTO SERIALE**, PER **NECESSITÀ PRODUTTIVE**, HANNO UN FORMATO FISSO, UN NUMERO DI PAGINE DEFINITO E DEI VINCOLI PRECISI PER POTER MANTENERE IL **FLUSSO DI LAVORO** DEI COLLABORATORI E LA CADENZA **PERIODICA** DELLE USCITE.

					
STILE DI DISEGNO: <b>IN LINEA CON LA SERIE.</b>	CONTENUTI: <b>IN LINEA CON LA SERIE.</b>	FORMATO GABBIA: <b>FISSO.</b>	NUMERO DI PAGINE: <b>FISSO.</b>	TIPOLOGIA DI STAMPA: <b>DATO</b> (BIANCO E NERO o COLORE).	TEMPI DI CONSEGNA: <b>FISSATI DALLA CASA EDITRICE.</b>

CON I **ROMANZI A FUMETTI** INVECE GLI AUTORI SONO PIÙ LIBERI:

					
STILE DI DISEGNO: <b>LIBERO.</b>	CONTENUTI: <b>LIBERI.</b>	FORMATO GABBIA: <b>LIBERO.</b>	NUMERO DI PAGINE: <b>LIBERO.</b>	TIPOLOGIA DI STAMPA: <b>LIBERA.</b>	TEMPI DI CONSEGNA: <b>LIBERI.</b>

QUESTO OFFRE DELLE OPPORTUNITÀ CREATIVE **INFINITE**, ANCHE SE, IL PIÙ DELLE VOLTE, GETTA GLI AUTORI NEL **PANICO CREATIVO**.



DEI **VINCOLI DEVONO ESSERCI** E SE NON ARRIVANO DALLA CASA EDITRICE DEVONO ARRIVARE DALLA **SENSIBILITÀ DELL'AUTORE**.



<p>COME UNO SCRITTORE DI <b>NARRATIVA</b>, UN AUTORE DI ROMANZI A FUMETTI... ... NON PENSA A <b>QUANTE PAGINE</b> AVRÀ IL SUO LIBRO.</p>		<p>MA LASCIA CHE SIA LA <b>STORIA</b> A PRENDERSI LO <b>SPAZIO NECESSARIO</b> PER ESSERE RACCONTATA.</p>
--	---	--

# **Il fumetto a scuola**

- 1. Incontri sul linguaggio**
- 2. Percorsi su Fumetto e didattica**

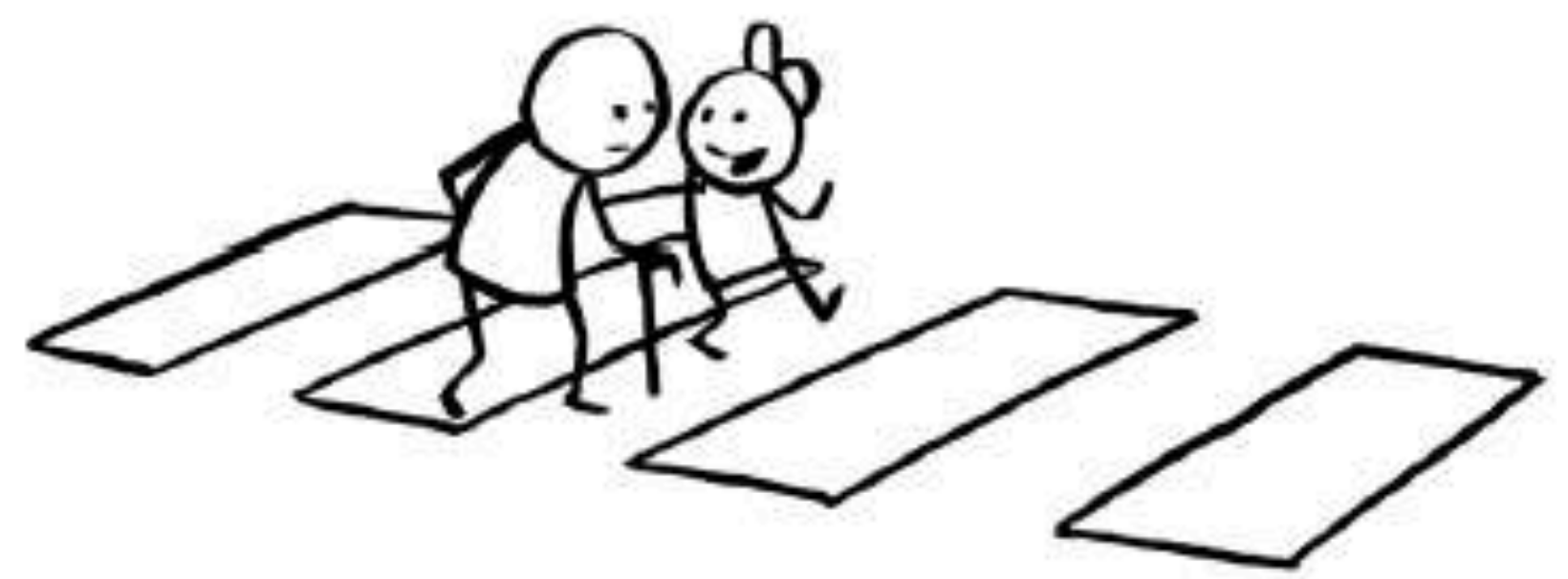

ACCELERERA!



LI INVESTE.

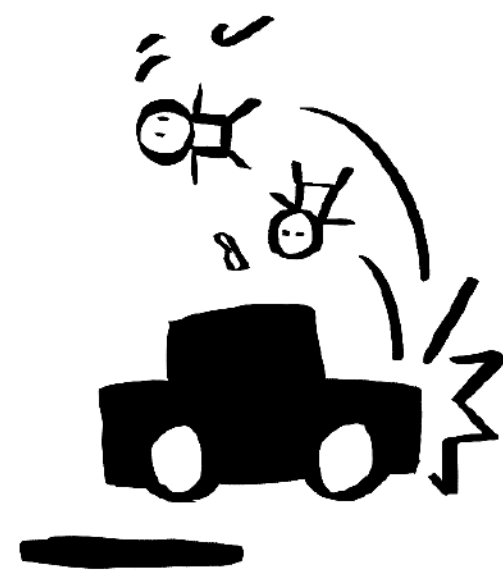

CORRE VIA.



LUCILLA È  
CATTIVISSIMA  
E SENZA PIETÀ.



ACCELERERA!



LI SCHIVA CON  
UNA MANOVRA  
SPETTACOLARE.

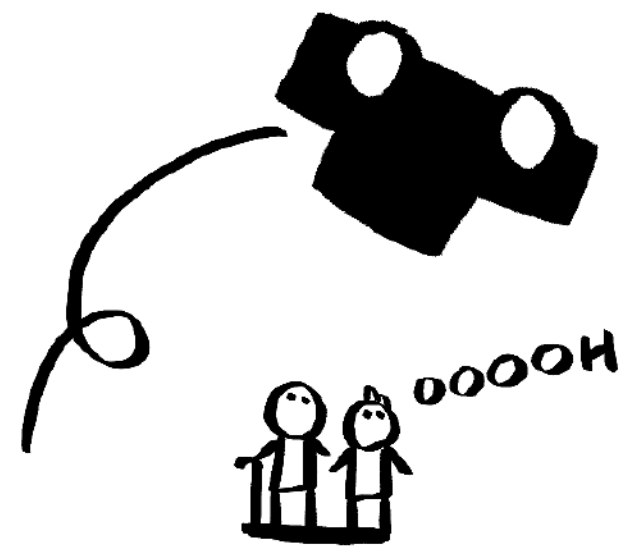

CORRE VIA.



LUCILLA È  
BUONA ED È  
UNA GRANDE  
PILOTA.



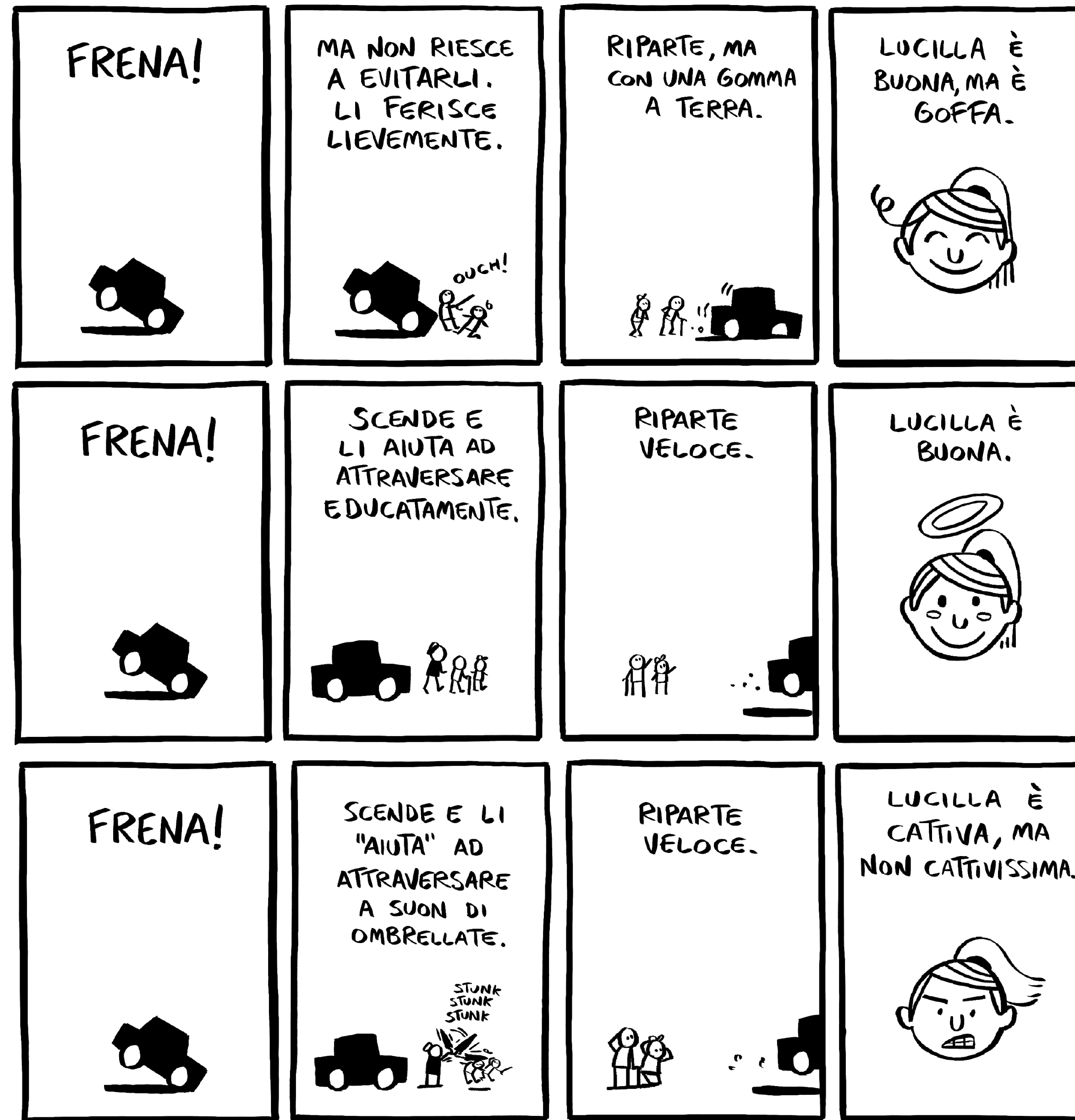



# 1. Sul linguaggio

Shape, zoom in-out, vignetta inizio e fine, una storia in numero variabile di vignette, ricetta a fumetti.

**Zoom out**

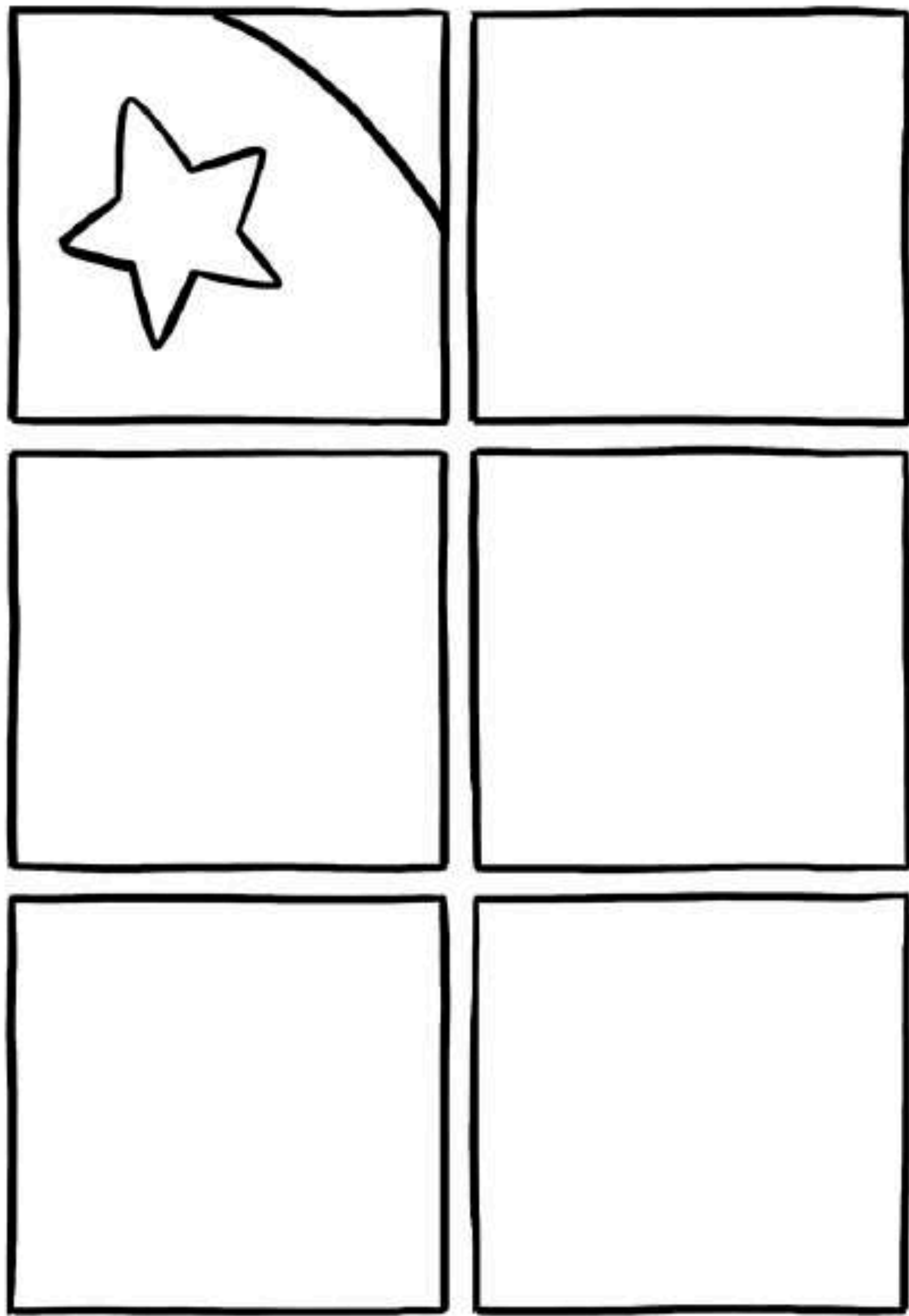

# **Dobbiamo parlare**

- *Dobbiamo parlare.*
- *Non ho più voglia di parlare con te!*
  - *Perché?*
  - *Lo sai il perché!*





# Leggere

- *Giro di lettura*
- *Lettura ad alta voce*

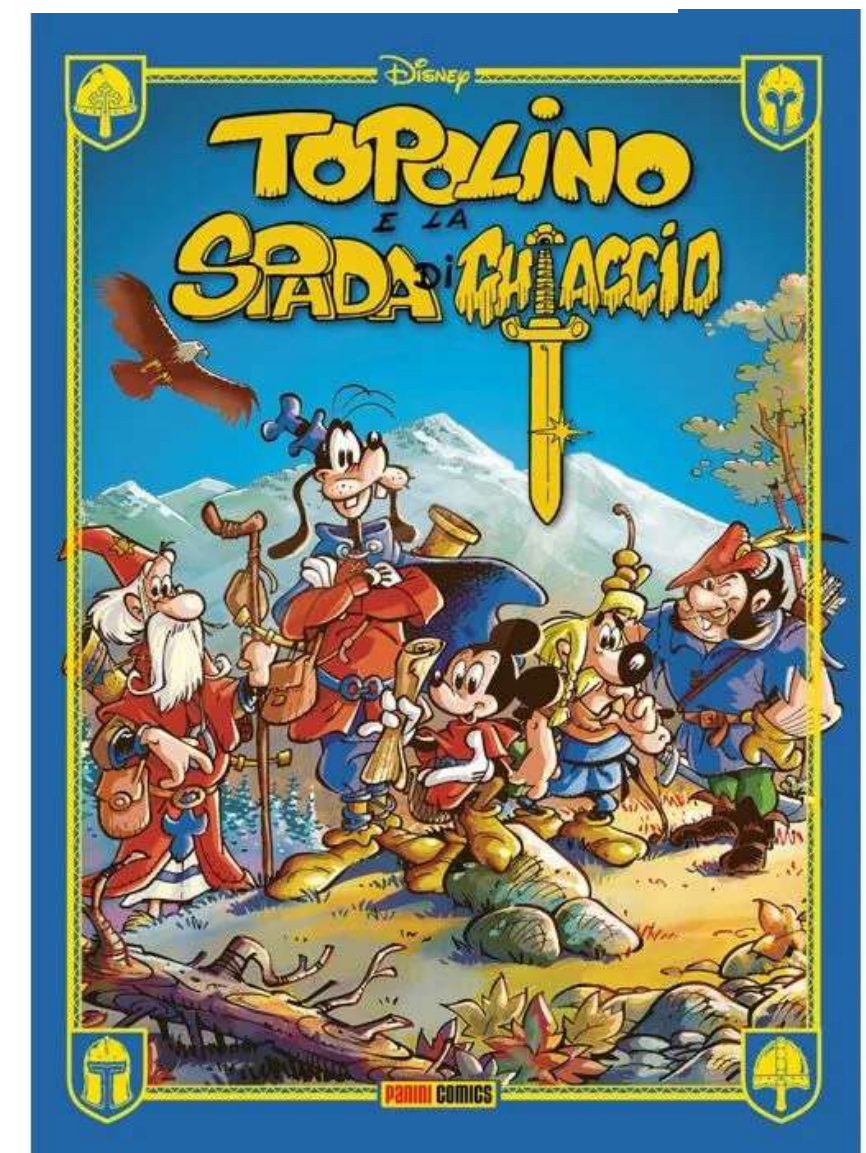
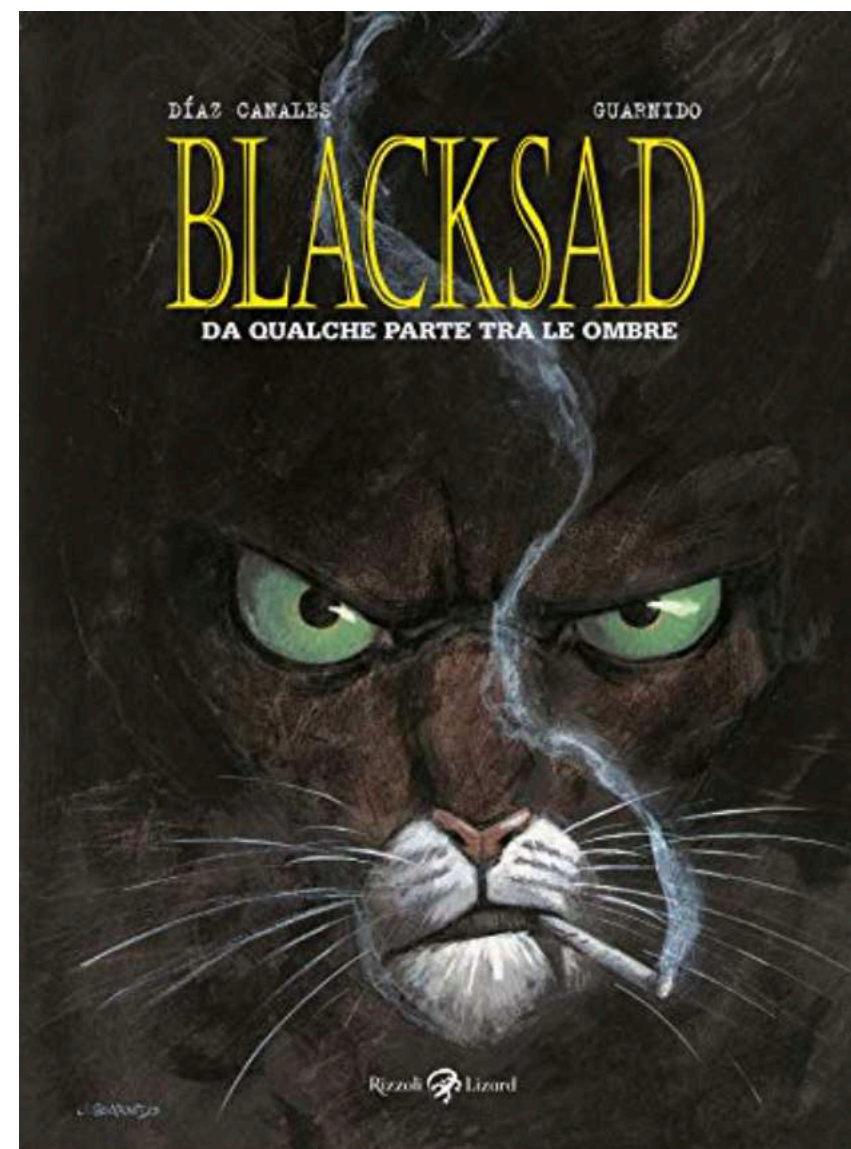
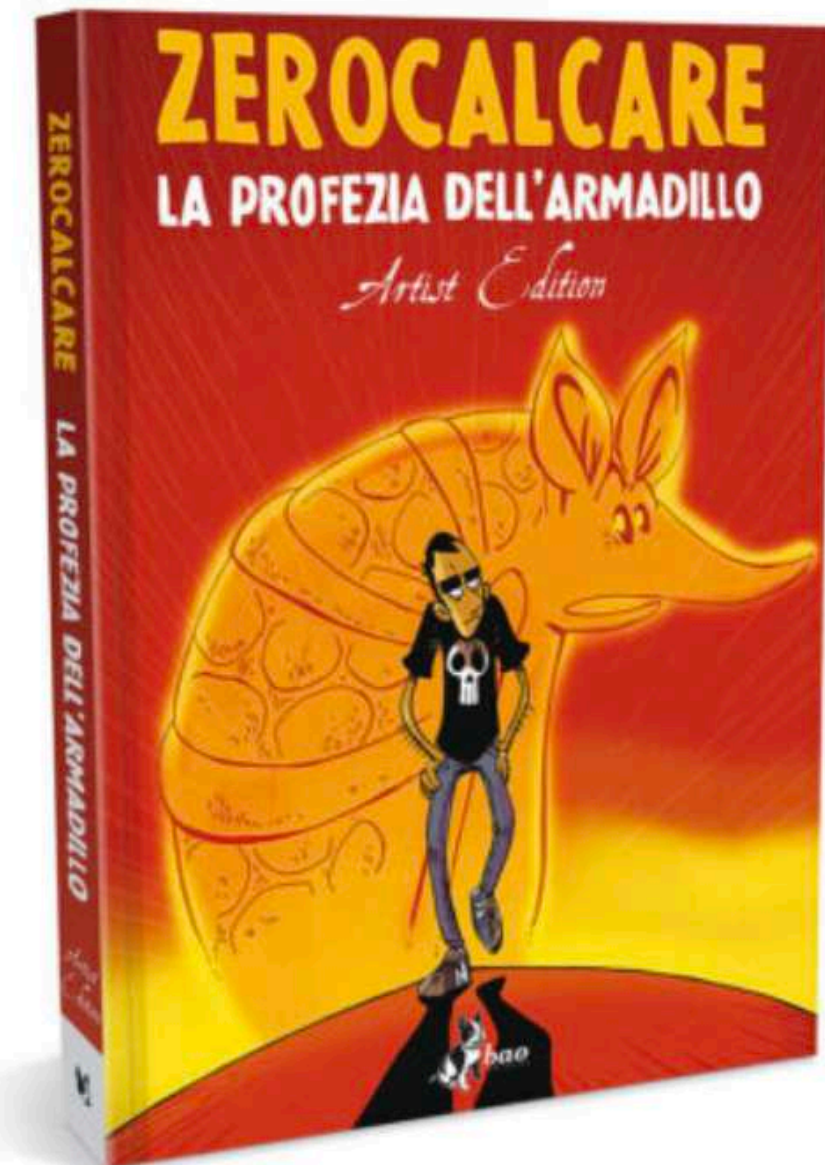
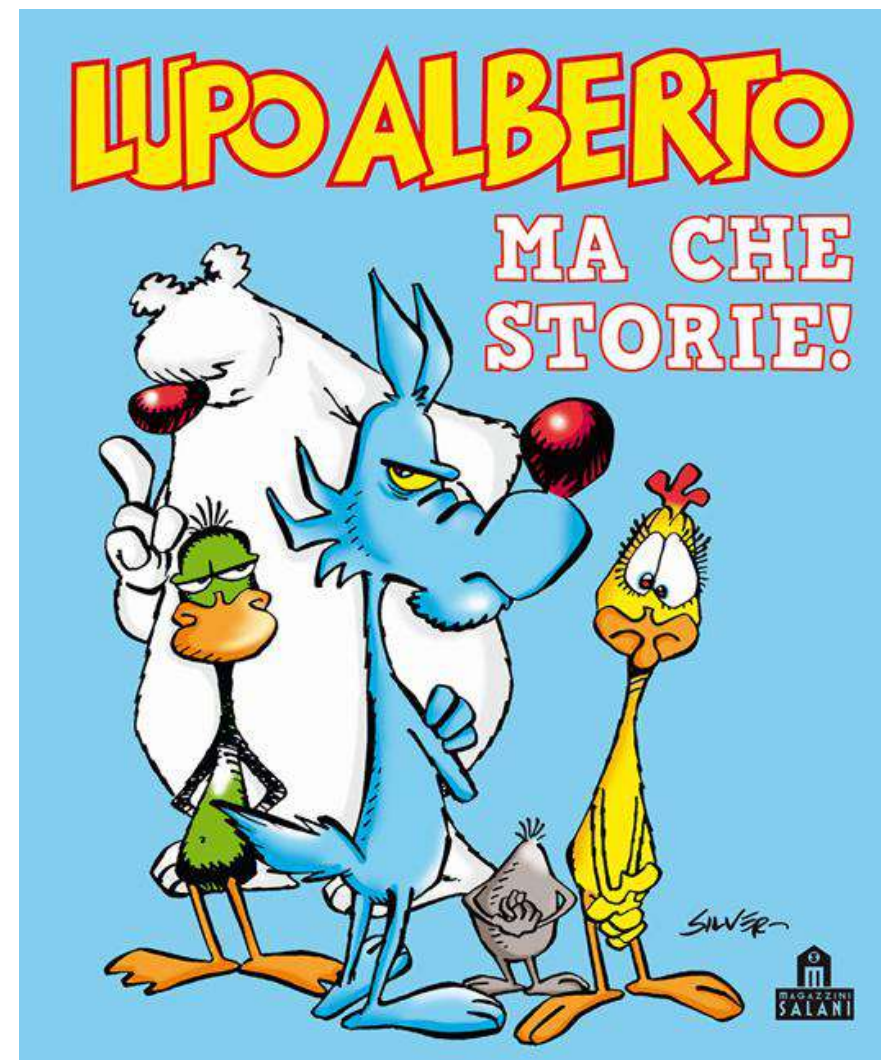
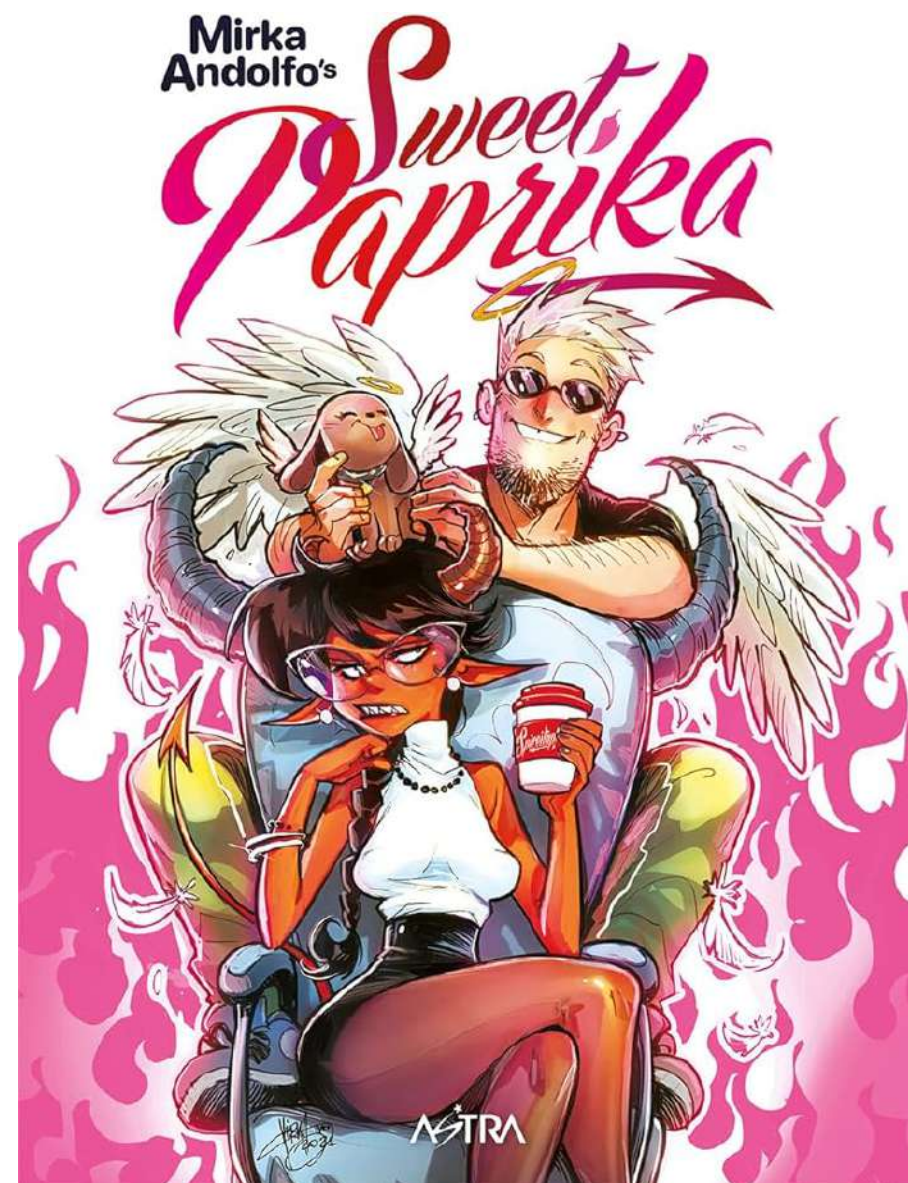
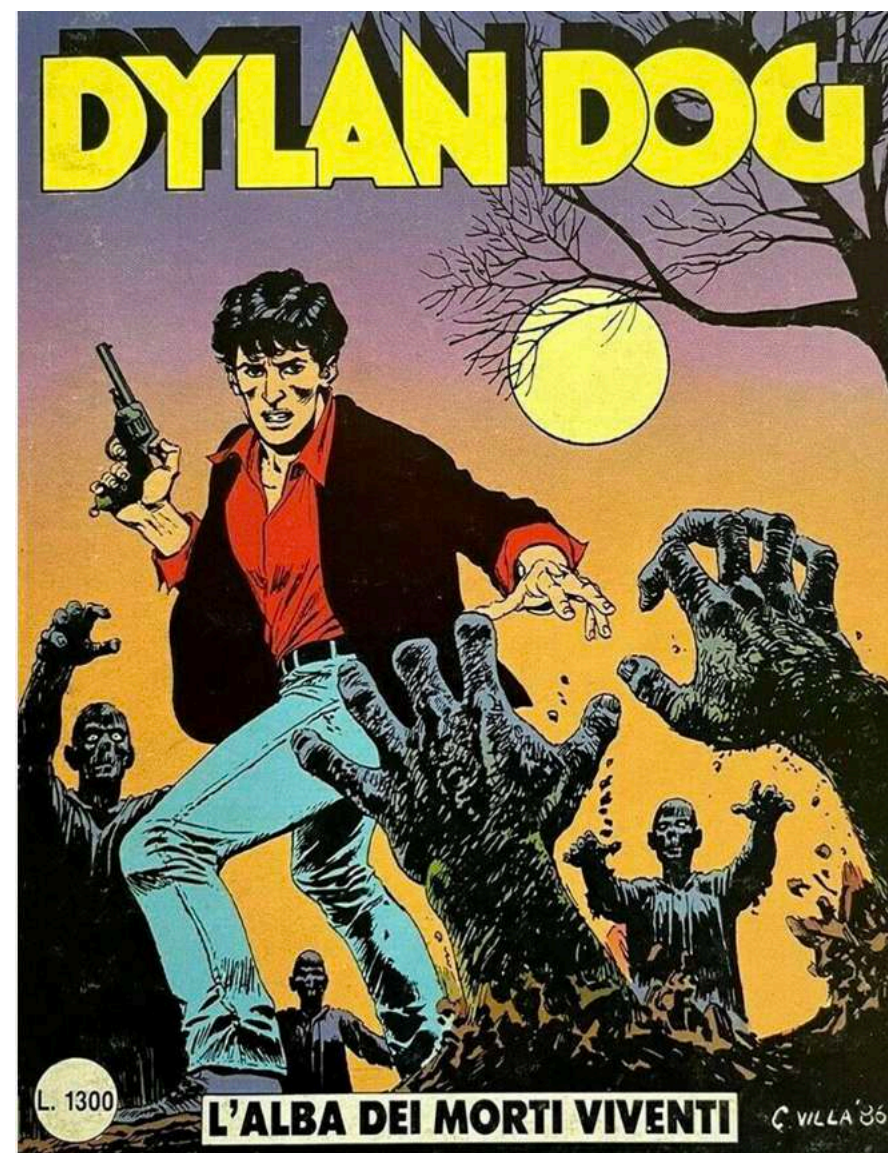

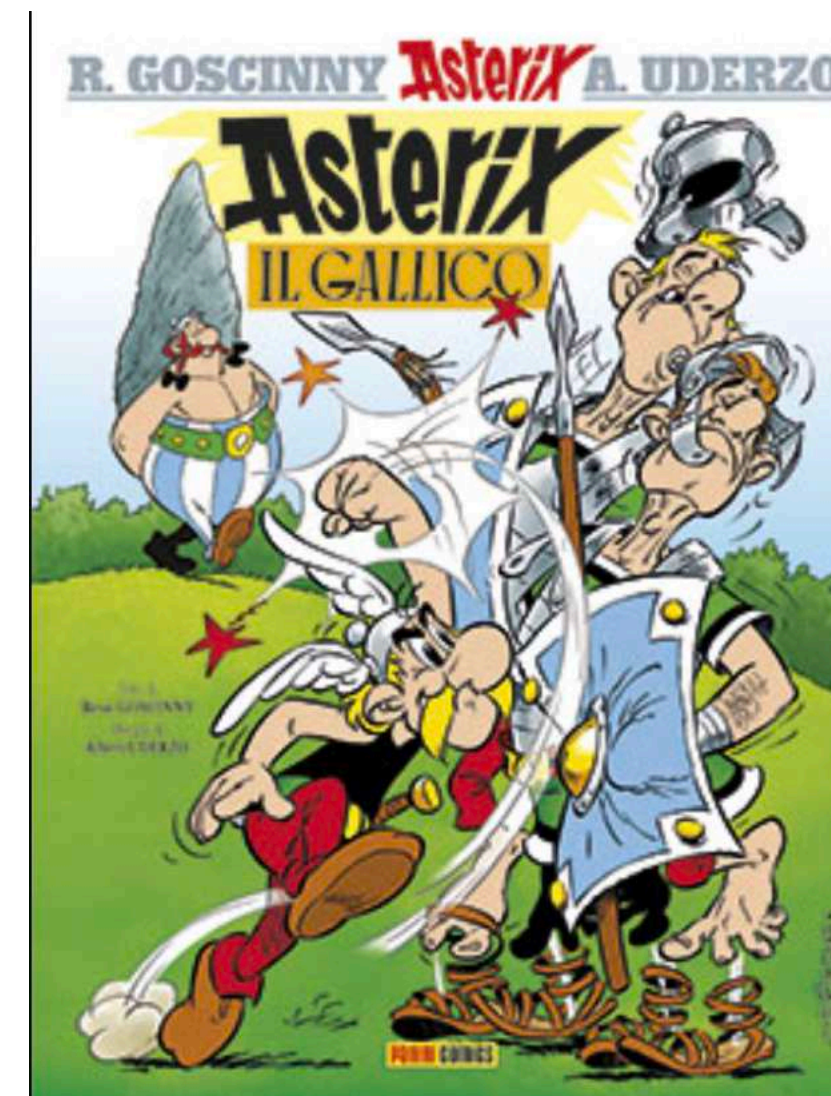
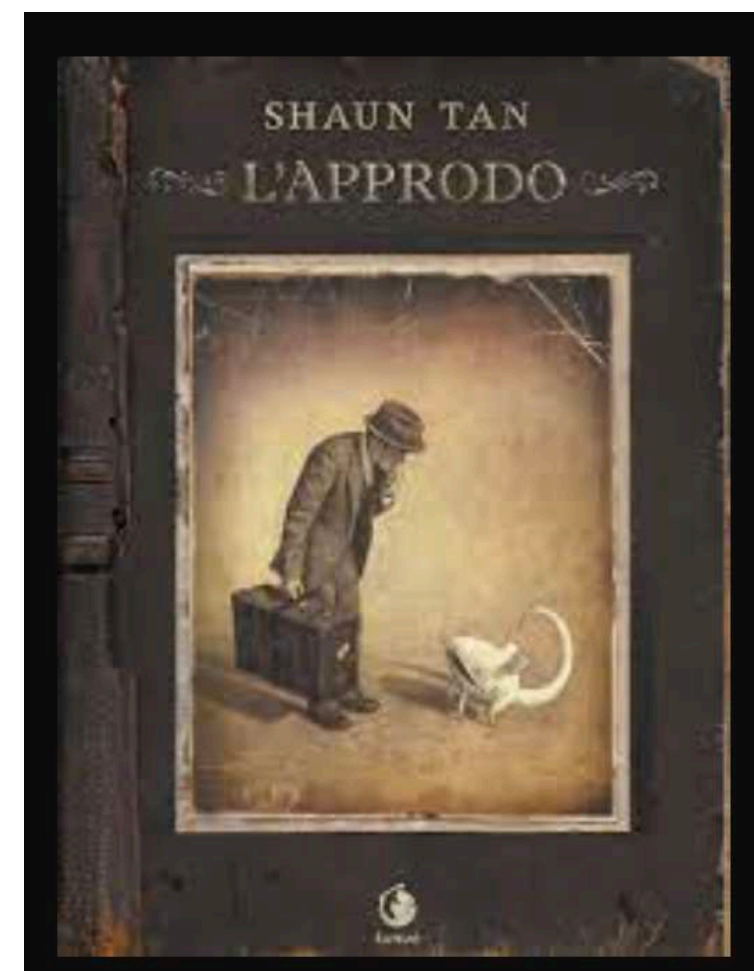
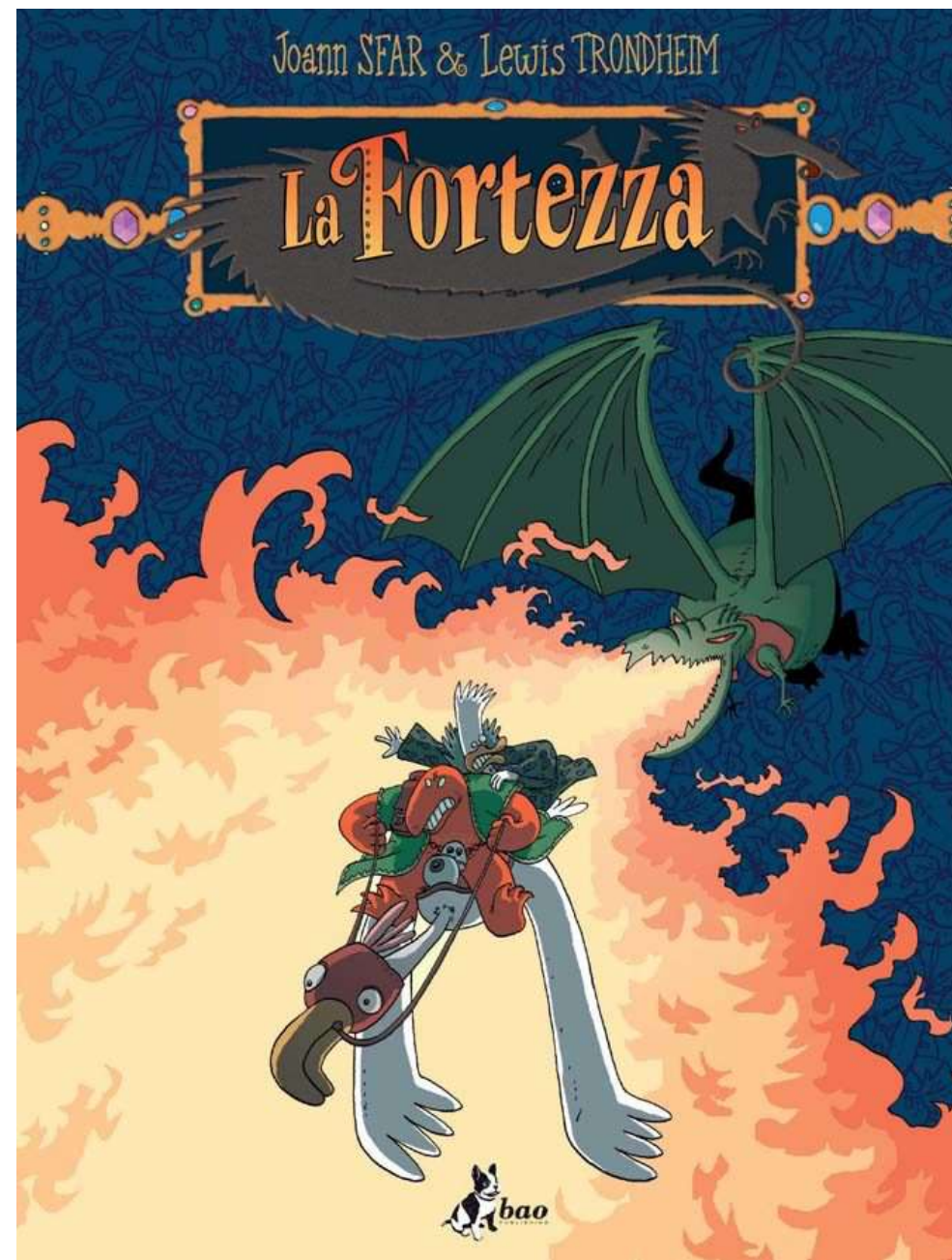
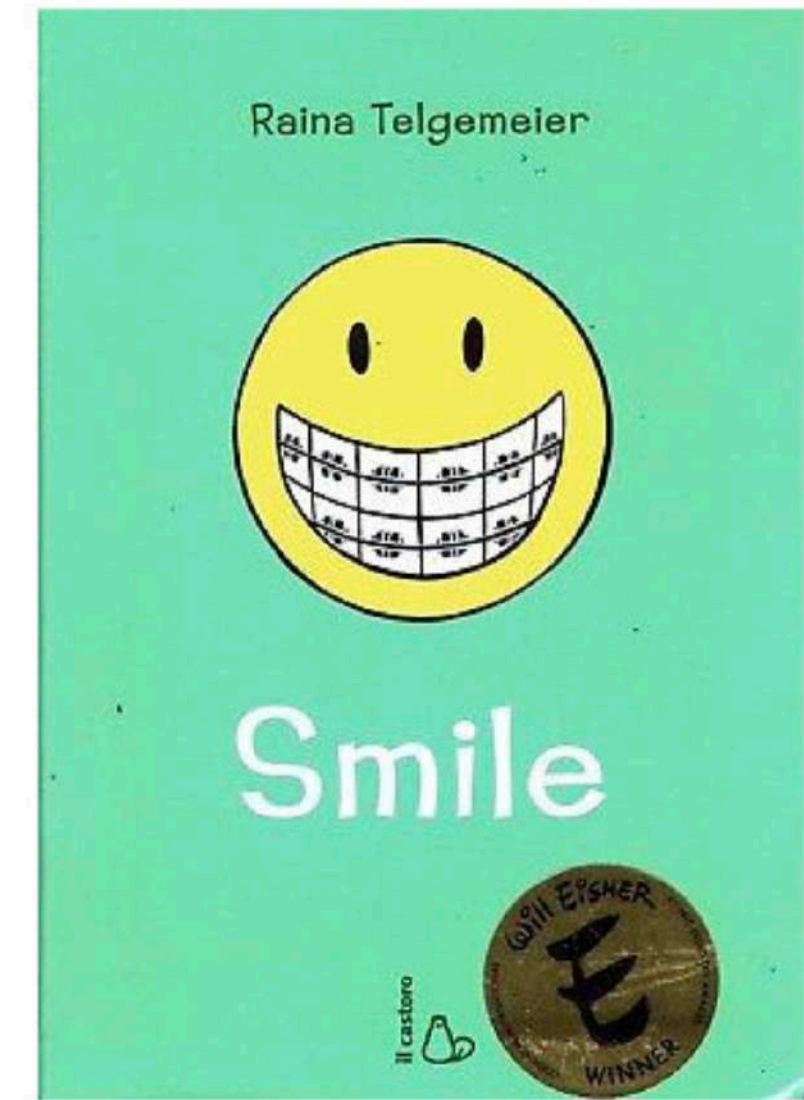
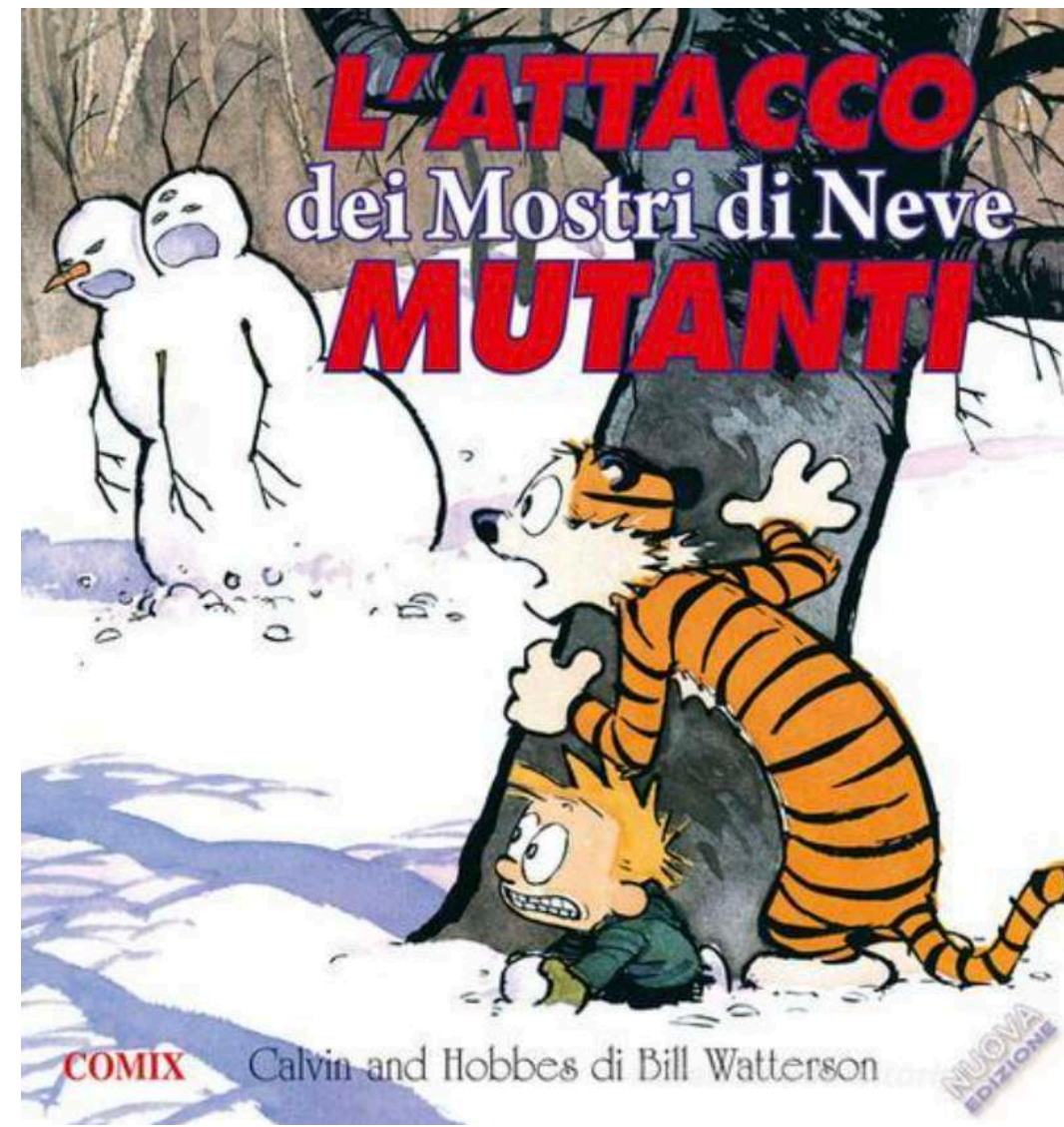



## 2. Fumetto e didattica

- *Leggere fumetti*: Analisi, individuale o di gruppo, dopo la lettura di fumetti su argomenti del programma (storia, musica, giornalismo, scienze, adattamenti opere letterarie, cinematografiche o teatrali, ...);
- *Fare fumetti*: giornale di classe, reportage, inchiesta giornalistica a fumetti, diario, adattamenti.

**UNA VIGNETTA PER UNO,  
UN FUMETTO PER TUTTI**  
*Creare una storia in gruppo*

**DILLO CON PAROLE TUE**  
*Creare fumetti condivisi*

**CHE STORIA ASSURDA!**  
*Fumetto narrativo*

**CHE EMOZIONE!**  
*Un progetto interdisciplinare*

**MAPPE E FUMETTI**  
*Utilizzare il fumetto per l'apprendimento*

**TUTTO QUELLO CHE MI CIRCONDA**  
*Fumetto descrittivo*

**COSÌ SI FA**  
*Fumetto regolativo*

**LE VERDURE SONO DIVISIVE**  
*Fumetto argomentativo*

**FERMO, CAMMINA E SCAPPA**  
*Dare ritmo alla narrazione*

**SI SCRIVE QUAL È O QUAL'È?**  
*Fumetto informativo*

**ROMEO, ROMEO! PERCHÉ SEI TU ROMEO?**  
*Impostare una regia*

**IL LIBRO DELLA CLASSE**  
*Raccontare l'altro da sé*

**RACCONTO DI UN'ATTIVITÀ STRAORDINARIA**  
*Creare un reportage a fumetti*

**IL DIARIO DI NATALE**  
*Creare un diario a fumetti*

**I TRE PORCELLINI**  
*Adattare una storia a fumetti*

**TROPPO VICINO, TROPPO LONTANO**  
*Gestire la telecamera*

# Domande?

# Altre domande?

# GRAZIE!

[www.gud.it](http://www.gud.it)

[gud@gud.it](mailto:gud@gud.it)

Ci vediamo su instagram: [@guddaman](https://www.instagram.com/guddaman)